

SECTION B-B

NOTES

1. EXTERNAL DROP STRUCTURE REQUIRED WHEN CROWN OF INLET PIPE IS 0.75m OR MORE ABOVE CROWN OF OUTLET PIPE.
2. USE 4 - 15M BARS PLACED AS SHOWN WHEN EXTERIOR DROP SECTION IS 1.5m OR MORE.
3. ALL CAST IN PLACE CONCRETE TO BE 35 MPa SULPHATE RESISTANT. ALL GROUT TO BE NON-SHRINK, TYPE HS SULPHATE RESISTANT, CEMENTITIOUS GROUT.
4. PLACE 10M BARS AT 200mm O.C. EACH WAY IN BASE OF MANHOLES OVER 4.5m DEEP.
5. ALL PRECAST CONCRETE SECTIONS SHALL BE MANUFACTURED IN ACCORDANCE WITH ASTM SPECIFICATION C478.
6. SAFETY PLATFORMS AS PER CITY OF SASKATOON STANDARD SPECIFICATIONS SHALL BE INSTALLED IN ALL MANHOLES WITH DEPTHS GREATER THAN 6.0 METERS.
7. SAFETY PLATFORMS SHALL BE INSTALLED IN SUCH A MANNER SO THAT NO VERTICAL FALL DISTANCE EXCEEDS 5.0 METERS OR IS LESS THAN 2.4 METERS.
8. MANHOLE RUNGS SHALL BE ORIENTED SUCH THAT THEY DO NOT INTERFERE WITH THE INCOMING PIPE.
9. PVC CHANNELING SHALL BE SEAMLESS FOR STRAIGHT THROUGH BASES.
10. PIPE TO MANHOLE CONNECTIONS SHALL BE WATERTIGHT.
11. TAPERED RUBBER ADJUSTMENT RISER RINGS ARE REQUIRED ON CATCH BASINS AND MANHOLES THAT ARE OFFSET FROM THE CENTER OF THE ROAD.

CHANNELIZATION DETAILS FOR INTERIOR DROP OF LESS THAN 0.75M

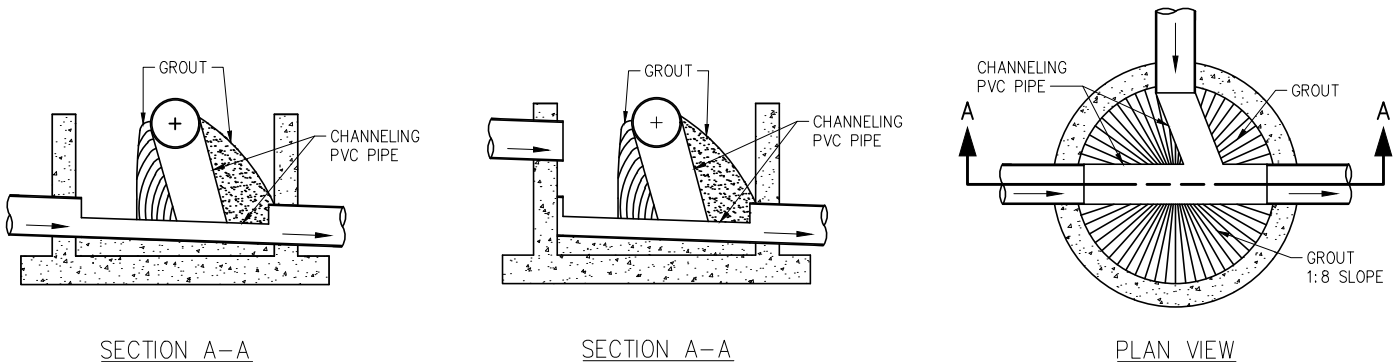

SECTION A-A

SECTION A-A

PLAN VIEW

PLAN DESCRIPTION/REVISION	DATE	BY	APPROVALS	
3	2006-APR-04	HLO	<p>STANDARD 1200mm MANHOLE FOR 200mm TO 600mm SANITARY SEWERS WITH DROP STRUCTURE</p>	<p>APPROVALS</p> <p><i>Jeff P D Thomson</i> SIGNATURE Jeff P D Thomson NAME Jan 27, 2021 DATE SIGNED</p> <p><i>Maciej Jurkiewicz</i> SIGNATURE Maciej Jurkiewicz NAME Jan 27, 2021 DATE SIGNED</p> <p>SCALE: HOR. 1:40 VERT. PLAN NO. 102-0011-005r010</p>
4	2007-JAN-22	HLO		
5	2009-NOV-16	MLB		
6	2012-JAN-05	HLO		
7	2014-DEC-12	MJ		
8	2015-NOV-26	HLO		
9	2017-JAN-25	HLO		
9	2017-JAN-25	HLO		
10	2021-JAN-11	DLH		