

Southwest Transportation Study



City of Saskatoon

April 19, 2018

Southwest Transportation Study

City of Saskatoon

April 19, 2018



Prepared By: Jay Magus, Acting Director, Transportation

EXECUTIVE SUMMARY

After a comprehensive study of the southwest area of the City, the following recommendations, cost estimates, and timeframes are provided in **Table ES-1**.

Table ES-1: Recommendations, Cost Estimates and Timeframes

Location	Recommendation	Justification	Cost Estimate	Timeframe
11 th Street & Avenue W (west intersection)	Installing a traffic signal; major intersection improvement	Reduce delays and improve the efficiency of the intersection	\$182,000	2 - 5 years
11 th Street & Avenue P	Geometric modifications on the east leg; install an eastbound left turn signal arrow	Reduce eastbound through movement to a single lane; mitigate cut through traffic; improve the efficiency of the intersection	\$10,000	0 - 2 years
11 th Street & Avenue H	Permanent Closure at 11 th Street & Avenue I (east leg); permanent closure at 12 th Street & Avenue H (South leg)	To fully enclose the Water Treatment Plant	\$3,000	0 - 2 years
Avenue H & 15 th Street	Install a raised median island on Avenue H	Improve pedestrian safety and reduce short-cutting traffic	\$3,000	0 - 2 years
Avenue H & 16 th Street	Install curb extensions	Improve pedestrian safety and reduce short-cutting traffic	\$10,000	0 - 2 years
17 th Street & Avenue H	Install guide sign on the southbound approach indicating to turn right to access Circle Drive South	Reduce short-cutting traffic along Avenue H and direct traffic to use a more direct and higher capacity roadway	\$1,000	0 - 2 years

Table ES-1 Continued

Location	Recommendation	Justification	Cost Estimate	Timeframe
17 th Street & Avenue J	Install a raised median island on 17th Street	Improve pedestrian safety and reduce speeding	\$3,000	0 - 2 years
17 th Street & Avenue L	Install a raised median island on 17th Street	Improve pedestrian safety and reduce speeding	\$3,000	0 - 2 years
17 th Street Extension	Modifications to the transportation network	Reduce short-cutting along 11 th Street and Avenue H by providing a more direct and higher capacity roadway	\$9,000,000 - \$11,000,000	5 - 10 years
11 th Street (Avenue W - Avenue P)	Construct sidewalks on 11 th Street (Ave W - Ave P)	Provide a better pedestrian connection	\$550,000	0 - 5 years

TABLE OF CONTENTS

1	INTRODUCTION.....	1
2	11 th STREET AND THE AVENUE W's.....	4
2.1	Background.....	4
2.2	Scope and Methodology	4
2.3	Existing Road Network and Intersection Geometrics	5
2.4	Existing Traffic Volumes	5
2.5	Existing Conditions – Warrant Review	7
2.6	Existing Operating Conditions – Synchro Review	7
2.7	Assessment	9
3	SASKATOON WATER TREATMENT PLANT ROAD CLOSURES.....	10
3.1	Background.....	10
3.2	Scope and Methodology	13
3.3	Existing Conditions	14
3.3.1	Road Network and Intersection Geometrics	14
3.3.2	Existing Traffic Volumes	17
3.3.3	Existing Operating Conditions	19
3.4	Future Conditions.....	21
3.4.1	Future Road Network.....	21
3.4.2	Future Intersection Geometry	21
3.4.3	Future Traffic Volumes	21
3.4.4	Future Operating Conditions.....	24
3.5	Cut-Through Traffic Mitigation.....	26

4	17 th STREET EXTENSION	29
4.1	Background.....	29
4.2	Existing Conditions	31
4.3	Future Land Use	31
4.4	Future Traffic Volumes.....	31
4.5	Future Traffic Analysis	32
4.6	Design Criteria	34
4.7	Functional Plans	36
5	OTHER ISSUES	37
5.1	Sidewalks.....	37
5.2	17 th Street Traffic Calming	38
5.3	17 th Street and Avenue P Intersection	38
5.4	17 th Street and Avenue H Intersection	40
6	RECOMMENDATIONS, COST ESTIMATES and TIMEFRAMES	42

LIST OF TABLES

Table 2-1: 11 th Street and Avenue W's Peak Hours	5
Table 2-2: Intersection Operating Conditions	8
Table 3-1: Existing Traffic Count Information	17
Table 3-2: Existing Operating Conditions	19
Table 3-3: 2014 Traffic Count Information (Future Traffic Volumes)	22
Table 3-4: Future Operating Conditions	24
Table 3-5: Traffic Count Review	26
Table 4-1: Future Operating Conditions	33
Table 4-2: Design Criteria	34
Table 5-1: 17 th Street and Avenue P Intersection Operating Conditions	39
Table 5-2: 17 th Street and Avenue P Intersection Collisions Statistics	39
Table 5-3: 17 th Street and Avenue H Intersection Operating Conditions	40
Table 5-4: 17 th Street and Avenue H Intersection Collisions Statistics	41
Table 6-1: Recommendations, Cost Estimates and Timeframes	42

LIST OF EXHIBITS

Exhibit 1-1: Study Area.....	3
Exhibit 2-1: AM Peak Hour Traffic Volumes	6
Exhibit 2-2: PM Peak Hour Traffic Volumes	6
Exhibit 2-3: On 11 th Street Looking North at Avenue W west intersection on Left and Suncor Access on Right.....	9
Exhibit 3-1: Previous Road Closure Plan	11
Exhibit 3-2: Existing Road Network	15
Exhibit 3-3: Existing Peak Hour Traffic Volumes	18
Exhibit 3-4: Future Peak Hour Traffic Volumes	23
Exhibit 4-1: West Industrial Concept Plan	30
Exhibit 4-2: Future Traffic Volumes	32
Exhibit 4-3: 17 th Street Extension Plan	35
Exhibit 5-1: 11 th Street Looking West	37

Appendix A - Traffic Analysis Methodology

Appendix B – Functional Plan of Near-Term Improvements for 11th Street and Avenue W West Intersection

Appendix C – Functional Plan of Near-Term Improvements Required to Support Water Treatment Plant Road Closures

Appendix D - Functional Plan of 17th Street Extension

Appendix E - Functional Plan of Near Term Improvements along 17th Street

1 INTRODUCTION

The initial scope of this project was limited to 11th Street and the intersections with Avenue W West and Avenue W East. The Administration had received inquiries as to the feasibility of installing traffic signals at the Avenue W west intersection, and removing the four-way stop control at the Avenue W east intersection. In the summer of 2014 the administration completed a cursory review and assessment of these intersections and provided a recommendation to proceed with a corridor study of 11th Street from Circle Drive South to Avenue H.

In the summer of 2015 the Administration launched the 11th Street Corridor Study, and public meetings were held to inform the public of the project and gather their input into transportation issues along 11th Street. The study began with the following objectives:

- Develop a transportation plan for the 11th Street Corridor:
 - Immediate improvements required to address existing transportation demand
 - Staged improvements required over ten years to meet future transportation demands along the corridor.
- Identify strategies to divert traffic away from the 11th Street residential areas in the King George and Holiday Park neighbourhoods to the Avenue P – 17th Street Corridor.
- Identify other potential vehicular travel routes through the area.

Also, in the summer of 2015 the Administration reviewed the *West Industrial Concept Plan*, approved by City Council in May 20, 2008. The plan included the extension of 17th Street between Avenue P South and 11th Street. This information was absorbed into the study, and the project changed in title to the *Southwest Transportation Study*, and grew in scope to include the functional design of the 17th Street Extension.

On March 8, 2016 the Administration provided a report to the Standing Policy Committee on Transportation titled ‘South West Roadway Network Improvements’. The report section of this report included the following:

“Improvement to Water Treatment Plant Security and Operations

The Water Treatment Plant is critical infrastructure for the City of Saskatoon as it is vital to public health and the economy of the entire City. Operations have been

upgraded and expanded over the last 10 years to encompass all three corners of the Avenue H and 11th Street intersection. When considering the significant infrastructure under Avenue H that links the infrastructure west of Avenue H, including reservoirs, high lift pumps, and ultraviolet disinfection, with the infrastructure on the east side of Avenue H, including intakes, clarifiers, chemical feed, and filters, it is clear that the best description of the site is that a public roadway runs through the City's Water Treatment Plant.

In order to fully enclose the Water Treatment Plant, the intersection of Avenue H and 11th Street, and portions of the adjacent roadway, will need to be permanently closed to public.

While the road closures around the Water Treatment Plant, and the closure of Spadina Crescent, also required in support of the Water Treatment Plant security needs was being presented to the public, and then City Council, the Southwest Transportation Study was put on hold while these specific items were confirmed.

City Council at its Public Hearing Meeting held on May 23, 2017, received a report titled Proposed Closure of Right-of-Way – Portion of Spadina Crescent and Avenue H and 11th Street – Holiday Park Neighbourhood. Included in this report were two Road Closure Bylaws to support the road closures. Council passed the bylaws, and also resolved,

“That the following measures to mitigate the traffic and safety impacts on adjacent roadways be implemented concurrently with the closures outlined in Bylaws 9449 and 9450 should they be passed:

- 1. Installation of a guide sign on the southbound approach to the intersection of 17th Street and Avenue H indicated to turn right to access Circle Drive South;*
- 2. Installation of traffic calming devices, such as a curb extension, at the intersection of 16th Street and Avenue H, and a centre median at the intersection of 15th Street and Avenue H;*
- 3. Revision of the traffic signals at the intersection of 11th Street and Avenue P to promote the eastbound left-turn movements from 11th Street onto Avenue P; and*

4. Any reasonable mitigation efforts resulting from a Crime Prevention through Environmental Design (CPTED) study of the closed section of Spadina Crescent West.

This report summarizes all of the findings, conclusions, and recommendations from the various transportation related items in the southwest part of the City of Saskatoon. An exhibit of the study area, bound by 11th Street, Avenue H, 17th Street, and Avenue P is included below.

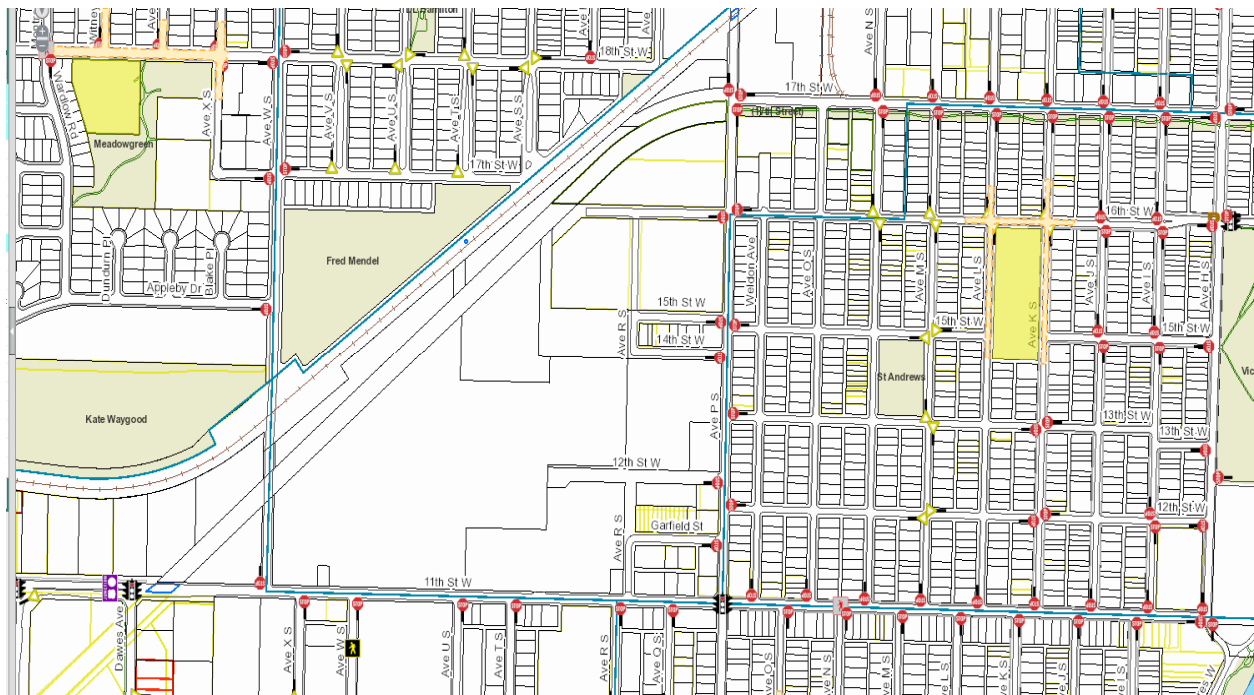

Exhibit 1-1: Study Area

2 11TH STREET AND THE AVENUE W'S

2.1 Background

11th Street experienced an increase in traffic due to the Gordie Howe Bridge opening in 2013. The new bridge provides a desirable connection across the South Saskatchewan River and connects the east and west sectors of Saskatoon. 11th Street is classified as Major Arterial between Fairlight Drive and Avenue P. This assessment specifically reviews the existing operations of the following intersections:

- Avenue W west intersection, which is aligned northerly at a 'T' intersection with 11th Street. It is currently stop-controlled on the southbound approach, and the eastbound and westbound movements are free-flow.
- Avenue W east intersection, which is aligned southerly from a 4-leg intersection with 11th Street. The northern leg provides access to a Suncor facility. This intersection is currently 4-way stop-controlled. Cameco's head office site is in the southeast quadrant of the intersection.

The Administration has received inquiries as to the feasibility of installing traffic signals at the Avenue W west intersection. In addition, the 4-way stop control at the Avenue W East intersection was also reviewed, as this was installed in 2013.

2.2 Scope and Methodology

The primary purpose for completing the assessment was to analyze intersection operating conditions under existing traffic volumes. The weekday AM and PM peak hour operating conditions for the above scenario were analyzed for the following intersections:

- Avenue W west intersection / 11th Street
- Avenue W east intersection / 11th Street

The assessment was completed using the following methodology:

- Gather existing traffic counts at the studied intersections.
- Analyze existing intersection capacity and identify any infrastructure deficits, if any.
- If required, identify the road and infrastructure requirements, including method of traffic control, to accommodate existing traffic volumes.

2.3 Existing Road Network and Intersection Geometrics

11th Street is classified as a Major Arterial between Fairlight Drive and Avenue P. Avenue W west is classified as a Minor Arterial north of 11th Street. Avenue W is classified as a Major Collector south of 11th Street.

Details on the assessed intersections are as follows:

- Avenue W west intersection, which is aligned northerly from a ‘T’ intersection with 11th Street. It is currently stop-controlled on the southbound approach, and the eastbound and westbound movements are free-flow.
- Avenue W east intersection, which is aligned southerly from a 4-leg intersection with 11th Street. The northern leg provides access to a Suncor facility. This intersection is currently 4-way stop-controlled. The Cameco office site is in the southeast quadrant of the intersection.

2.4 Existing Traffic Volumes

Traffic counts at the assessed intersections were conducted on June 9 and 10, 2014 during the periods of 7:00AM – 9:00AM and 3:00PM – 6:00 PM. The resulting weekday peak hours are detailed in **Table 2-1** below.

Table 2-1: 11th Street and Avenue W’s Peak Hours

Intersection with 11 th Street	AM Peak Hour	PM Peak Hour
Avenue W west intersection	7:45 – 8:45	4:30 – 5:30
Avenue W east intersection	7:30 – 8:30	4:15 – 5:15

The existing weekday AM and PM peak hour traffic volumes are illustrated in **Exhibit 2-1** and **Exhibit 2-2**.

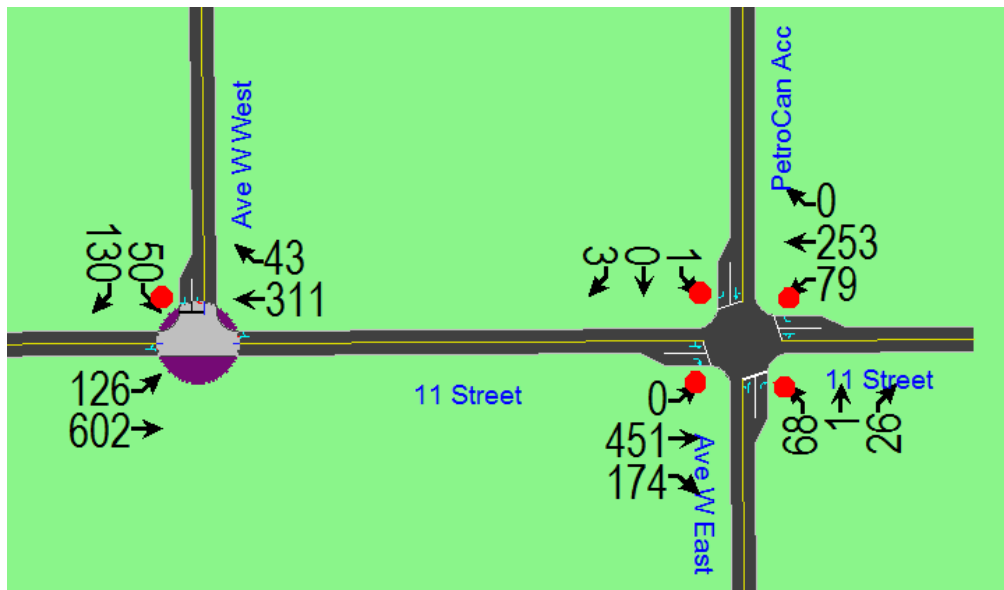

Exhibit 2-1: AM Peak Hour Traffic Volumes

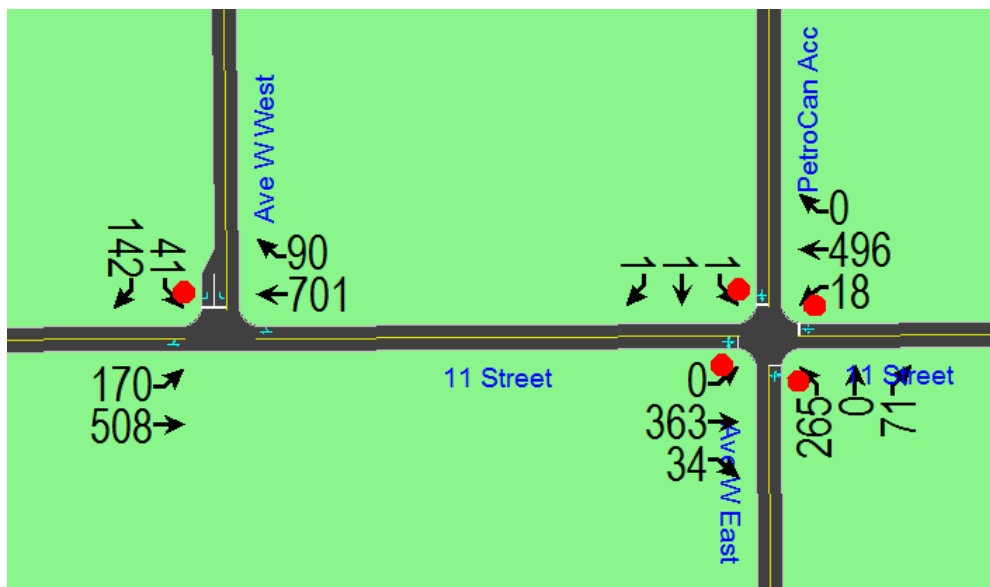

Exhibit 2-2: PM Peak Hour Traffic Volumes

2.5 Existing Conditions – Warrant Review

An all-way stop warrant was completed for the intersection of 11th Street and Avenue W west intersection. The inputs into the warrant analysis are detailed below.

- Existing traffic control: southbound movement is stop-controlled
- Average Daily Traffic: 15,880
- Peak Hour Traffic: 1,537
- 3 collisions in most recent 12-month data
- Traffic split: 13% from Avenue W west and 87% from 11th Street

The results of the warrant indicate an all-way stop is not warranted.

2.6 Existing Operating Conditions – Synchro Review

Operating conditions at the studied intersections were assessed based on the existing traffic volumes shown previously in **Exhibit 2-1** and **Exhibit 2-2**. The analysis reflects the existing road network, lane configurations, and traffic controls. The analysis results are shown in **Table 2-2**.

Table 2-2: Intersection Operating Conditions

Intersection	Movement		Operating Conditions			
			AM Peak Hour		PM Peak Hour	
			LOS	Delay (s)	LOS	Delay (s)
Avenue W west intersection / 11 th Street	EB	LT/Thru	A	2.6	A	5.0
	WB	Thru	A	0	A	0
		RT	A	0	A	0
	SB	LT/RT	C	16.5	D	30.3
Avenue W east intersection / 11 th Street	EB	LT-Thru	C	16.7	C	20.9
		RT	A	7.6	A	8.1
	WB	LT-Thru	B	13.4	E	44.0
		RT	B	13.4	E	44.0
	NB	LT-Thru	B	10.3	C	19.3
		RT	A	8.2	A	9.3
	SB	LT-Thru	A	9.4	B	10.5
		RT	A	8.2	A	9.5

Details on the traffic analysis methodology is provided in **Appendix A**.

As illustrated in **Table 2-2**, all intersection movements are operating at an overall LOS of D or better during the AM and PM peak hours, with the exception of the WB movements at the Avenue W east intersection in the PM peak hour. However, it is recognized that as traffic volumes continue to grow, the ability to enter 11th Street from Avenue W east intersection will continue to have a poor level of service.

2.7 Assessment

A significant traffic safety and operations issue for the 11th Street corridor is the access to the Suncor site which is immediately adjacent to Avenue W west intersection on the east side of the intersection as shown in **Exhibit 2-3**.



Source: Google Streetview

Exhibit 2-3: On 11th Street Looking North at Avenue W west intersection on Left and Suncor Access on Right

Currently eastbound trucks accessing the Suncor site need to turn left from 11th Street, if the trucks need to wait to complete the turn, they block the intersection of 11th Street and Avenue W west intersection. To mitigate this issue it is recommended that the intersection of 11th Street and Avenue W west intersection be signalized to facilitate the left-turning trucks destined for the Suncor site, and then a new access be constructed into the Suncor site off of Avenue W west intersection less than a hundred metres north of 11th Street. This would be a near-term recommendation that should only be considered if the long-term improvement of the 17th Street extension (discussed further in this document) is determined to not be constructed within five years.

Functional plans of the recommended changes are provided in **Appendix B**.

3 SASKATOON WATER TREATMENT PLANT ROAD CLOSURES

3.1 Background

The intersection of Avenue H and 11th Street was closed as part of the Avenue H Reservoir Expansion Project recently completed by the City of Saskatoon. A temporary road closure plan was developed to detour traffic as illustrated in **Exhibit 3-1**. 11th Street east of Avenue I, and Avenue H south of 12th Street were closed. Also, as part of the closure plan two temporary all-way stops were installed in March of 2012 at the following intersections:

- Avenue P and 17th Street
- Avenue H and 17th Street

The road closure, in place for over two and half years as the Reservoir Expansion Project was completed, was removed in November of 2014. Shortly thereafter in January 2015, as planned, the two temporary all-way stops were removed. However, both all-way stops were reinstated pending review.

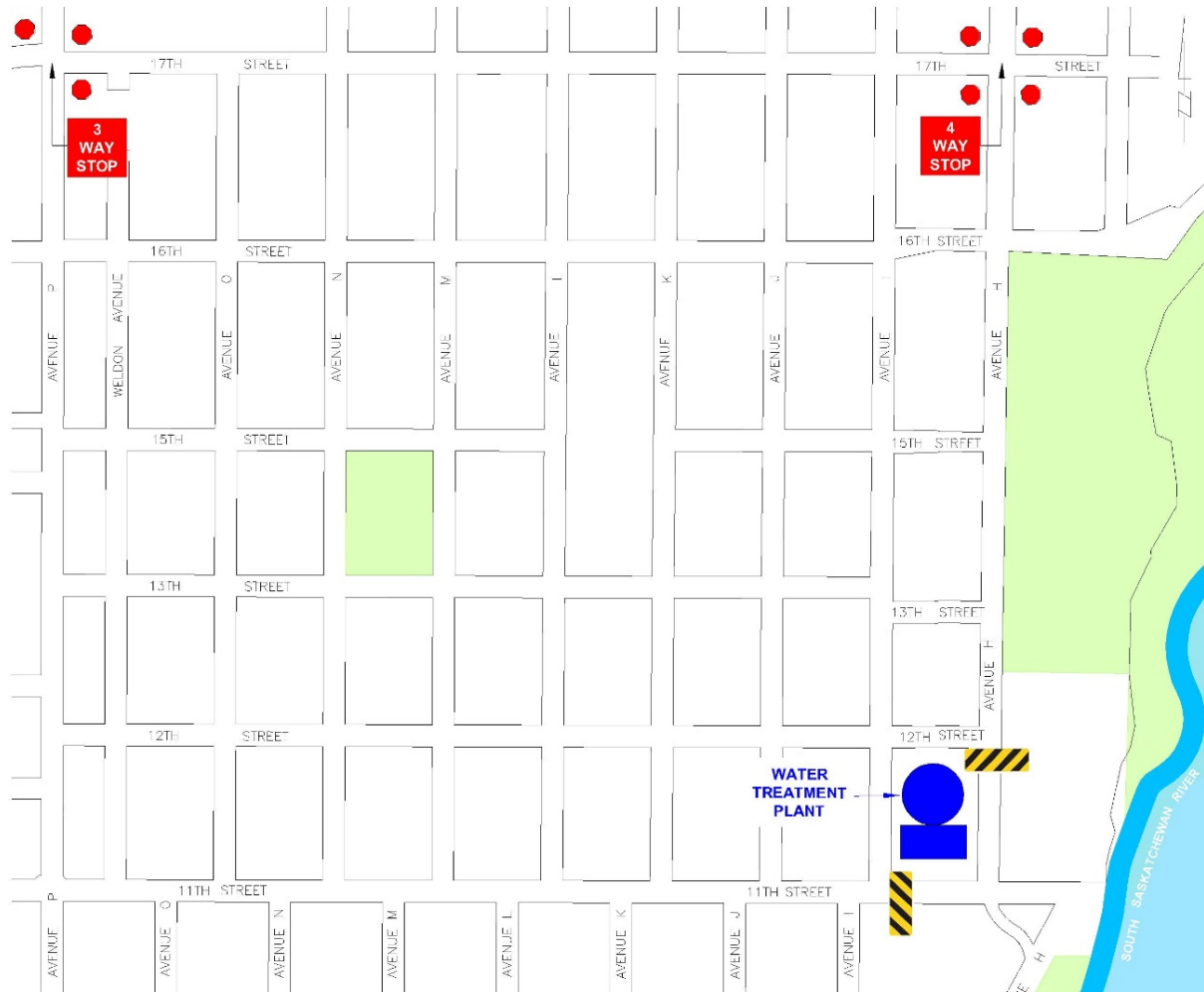

Exhibit 3-1: Previous Road Closure Plan

On March 8, 2016 the Administration provided a report to the Standing Policy Committee on Transportation titled 'South West Roadway Network Improvements'. The report section of this report included the following:

“Improvement to Water Treatment Plant Security and Operations

The Water Treatment Plant is critical infrastructure for the City of Saskatoon as it is vital to public health and the economy of the entire City. Operations have been upgraded and expanded over the last 10 years to encompass all three corners of the Avenue H and 11th Street intersection. When considering the significant infrastructure under Avenue H that links the infrastructure west of Avenue H, including reservoirs, high lift pumps, and ultraviolet disinfection, with the infrastructure on the east side of Avenue H, including intakes, clarifiers, chemical feed, and filters, it is clear that the best description of the site is that a public roadway runs through the City’s Water Treatment Plant.

In order to fully enclose the Water Treatment Plant, the intersection of Avenue H and 11th Street, and portions of the adjacent roadway, will need to be permanently closed to public.

A combined site security plan and traffic impact study will be completed in 2017 to evaluate and mitigate the impacts of the modifications.

West Industrial Concept Plan

The West Industrial Concept Plan was approved by City Council on May 20, 2008. The concept plan outlines long-term plans for modifications to the transportation network including an extension of 17th Street from Avenue P extending west to 11th Street. This connection would reduce short cutting traffic along 11th Street and Avenue H by providing a more direct, higher capacity roadway. The extension of 17th Street would be an arterial roadway constructed on abandoned Canadian National Railway right-of-way that the City purchased in 2002. Facilities for active transportation would also be incorporated into the new roadway.”

At this meeting the Committee verbally requested the Administration review the traffic impacts earlier than 2017 to determine if permanently closing the intersection of Avenue

H and 11th Street and portions of the adjacent roadway was feasible prior to 17th Street being extended.

City Council at its Public Hearing Meeting held on May 23, 2017, received a report titled Proposed Closure of Right-of-Way – Portion of Spadina Crescent and Avenue H and 11th Street – Holiday Park Neighbourhood. The information in this chapter was provided as background information to that report.

3.2 Scope and Methodology

The primary purpose for completing the study was to analyze intersection operating conditions for the following scenarios:

- Existing: Using current traffic counts at the analyzed intersections.
- Post closure: The projected traffic volumes after the road closures.

The weekday AM and PM peak hour operating conditions for the above scenarios were analyzed for the following intersections:

- 17th Street and Avenue H
- 17th Street and Avenue P
- 12th Street and Avenue I
- 11th Street and Avenue P

The traffic impact assessment was completed using the following methodology:

- Gather existing traffic counts at the five intersections identified for analysis.
- Analyze existing intersection capacity and identify any infrastructure deficits, if any.
- Review traffic counts that were collected during the previous road closures and determine their appropriateness.
- Analyze the post closure intersection capacity and identify the road and infrastructure requirements, including method of traffic control, to accommodate the post closure traffic volumes.
- Determine the appropriate traffic calming, if required, to mitigate cut-through traffic.

This report presents the study methodology, analysis, conclusions, and recommendations.

3.3 Existing Conditions

3.3.1 Road Network and Intersection Geometrics

The existing road network is described as follows:

- Avenue P – Is aligned north-south with a cross-section that includes one driving lane and one parking lane in each direction.
- Avenue H – Is aligned north-south with a cross-section that includes one driving lane and one parking lane in each direction.
- Avenue I – Is aligned north-south with a cross-section that includes one driving lane and one parking lane in each direction.
- 17th Street – Is aligned east-west with a cross-section that includes one driving lane and one parking lane in each direction.
- 11th Street – Is aligned east-west with a cross-section includes one driving lane and one parking lane in each direction.

The existing road network is illustrated in **Exhibit 3-2**.



Exhibit 3-2: Existing Road Network

The existing intersection geometry, lane arrangements, and traffic control is described below:

- 17th Street and Avenue H:
 - Four-way stop controlled
 - Eastbound shared left turn and through lane
 - Eastbound right turn lane with ten metres storage
 - Northbound shared left turn, through, and right turn lane
 - Westbound shared left turn and through lane
 - Westbound right turn lane with ten metres storage
 - Southbound shared left turn and through lane
 - Southbound right turn lane with ten metres storage
- 17th Street and Avenue P:
 - Three-way stop controlled
 - Eastbound shared left turn, through, and right turn lane (from adjacent business)
 - Northbound shared left turn and through lane
 - Northbound right turn lane with ten metres storage
 - Westbound shared left turn and through lane
 - Westbound right turn lane with ten metres storage
 - Southbound shared left turn and through lane
 - Southbound right turn lane with ten metres storage
- 12th Street and Avenue I
 - Two-way stop controlled (northbound and southbound approaches)
 - Eastbound shared left turn, through, and right turn lane
 - Northbound shared left turn, through, and right turn lane
 - Westbound shared left turn, through, and right turn lane
 - Southbound shared left turn, through, and right turn lane

- 11th Street and Avenue P
 - Traffic signal controlled
 - Eastbound shared left turn and through lane
 - Eastbound shared through and right turn lane
 - Northbound shared left turn and through lane
 - Northbound shared through and right turn lane
 - Westbound shared left turn and through lane
 - Westbound shared through and right turn lane
 - Southbound shared left turn and through lane
 - Southbound shared through and right turn lane

3.3.2 Existing Traffic Volumes

Traffic counts at the studied intersections were conducted in 2016 during the periods of 7:00 am – 9:00 am and 4:00 pm – 6:00 pm. The resulting traffic count information is summarized in **Table 3-1**.

Table 3-1: Existing Traffic Count Information

Intersection	AM Peak Hour	PM Peak Hour
17 th Street and Avenue H	7:30 am – 8:30 am (July 15, 2016)	4:30 pm – 5:30 pm (July 13, 2016)
17 th Street and Avenue P	7:30 am – 8:30 am (July 14, 2016)	4:15 pm – 5:15 pm (July 13, 2016)
11 th Street and Avenue H	7:30 am – 8:30 am (January 28, 2016)	4:30 pm – 5:30 pm (January 27, 2016)
12 th Street and Avenue I	7:30 am – 8:30 am (July 14, 2016)	3:45 pm – 4:45 pm (July 13, 2016)
11 th Street and Avenue P	7:45 am – 8:45 am (July 15, 2016)	4:30 pm – 5:30 pm (July 14, 2016)

The existing weekday AM and PM peak hour traffic volumes are illustrated in **Exhibit 3-3**.

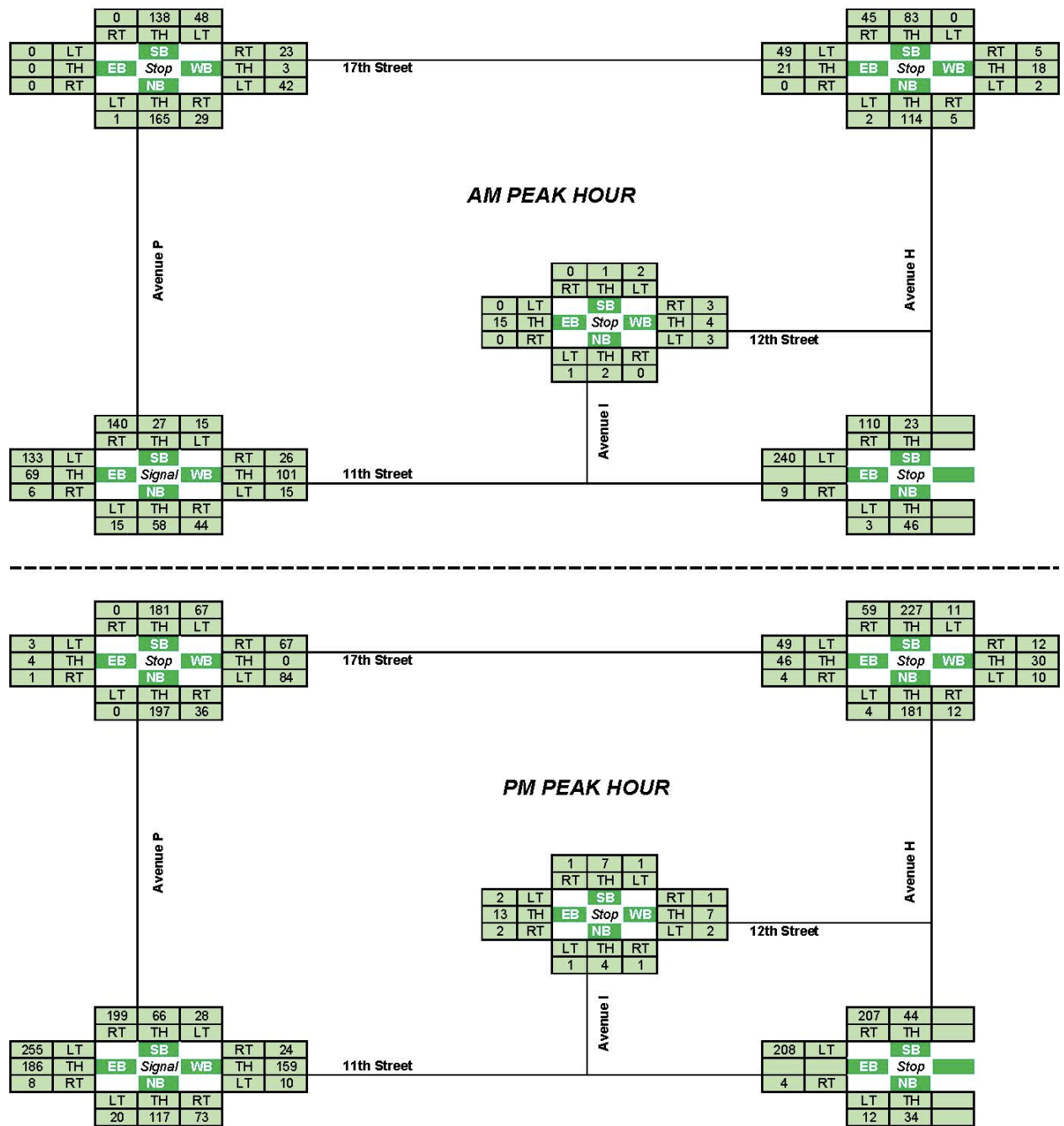

Exhibit 3-3: Existing Peak Hour Traffic Volumes

3.3.3 Existing Operating Conditions

Operating conditions at the studied intersections were assessed based on the existing traffic volumes shown previously in **Exhibit 3-3**. The analysis initially reflected the road network, lane configurations, and traffic controls discussed in **Section 3.3.1**. The analysis results are shown in **Table 3-2**.

Table 3-2: Existing Operating Conditions

Intersection / Movement			Measures of Effectiveness								
			AM Peak Hour				PM Peak Hour				
			v/c ratio	Delay (s)	LOS	Queue (m)	v/c ratio	Delay (s)	LOS	Queue (m)	
Avenue H / 17 th Street	EB	LT/Thru	0.11	7.9	A	0	0.16	9.0	A	0	
		RT	0.00	6.9	A	0	0.01	6.9	A	0	
	WB	LT/Thru	0.03	7.2	A	0	0.07	8.2	A	0	
		RT	0.01	6.3	A	0	0.02	7.0	A	0	
	NB	LT/Thru	0.16	7.6	A	0	0.27	9.0	A	0	
		RT	0.01	6.0	A	0	0.02	6.4	A	0	
	SB	LT/Thru	0.11	7.3	A	0	0.34	9.7	A	0	
		RT	0.05	6.2	A	0	0.07	6.6	A	0	
	Intersection Summary			0.16 (max)	7.4	A	-	0.34 (max)	8.9	A	-
	Avenue P / 17 th Street	EB	LT/Thru/RT	0.00	8.5	A	0	0.01	9.1	A	0
WB		LT/Thru	0.07	8.2	A	0	0.15	9.1	A	0	
		RT	0.03	6.7	A	0	0.09	7.4	A	0	
NB		LT/Thru	0.23	8.1	A	0	0.29	9.1	A	0	
		RT	0.03	6.1	A	0	0.05	6.6	A	0	
SB		LT/Thru	0.26	8.6	A	0	0.37	10.2	B	0	
		RT	0.00	6.7	A	0	0.00	7.0	B	0	
Intersection Summary			0.26 (max)	8.1	A	-	0.37 (max)	9.2	A	-	

Table 3-2 Continued

Intersection / Movement			Measures of Effectiveness								
			AM Peak Hour				PM Peak Hour				
			v/c ratio	Delay (s)	LOS	Queue (m)	v/c ratio	Delay (s)	LOS	Queue (m)	
Avenue P / 11 th Street	EB	LT/Thru	0.46	15.9	B	13.0	0.62	14.9	B	26.8	
		Thru/RT									
	WB	LT/Thru	0.23	14.8	B	8.5	0.19	11.7	B	10.6	
		Thru/RT									
	NB	LT/Thru	0.07	4.0	A	7.0	0.17	7.1	A	16.4	
		RT	0.03	3.8	A	3.2	0.05	6.3	A	5.5	
	SB	LT/Thru	0.04	3.8	A	4.6	0.12	6.8	A	12.1	
		RT	0.09	4.1	A	5.6	0.13	6.9	A	9.0	
	Intersection Summary			0.46 (max)	10.2	B	-	0.62 (max)	10.8	B	-
	Avenue I / 12 th Street	EB	LT/Thru/RT	0.00	0.0	A	0	0.00	0.9	A	0
WB		LT/Thru/RT	0.00	2.2	A	0	0.00	1.5	A	0	
NB		LT/Thru/RT	0.00	9.0	A	0	0.01	9.0	A	0	
SB		LT/Thru/RT	0.00	8.9	A	0	0.01	9.1	A	0	
Intersection Summary			0.00 (max)	2.4	A	-	0.01 (max)	3.9	A	-	

As illustrated in **Table 3-2** all intersection movements are operating at an overall LOS of B or better and with a v/c ratio of 0.62 or less during the AM and PM peak hours.

It is concluded no immediate intersection improvements are required.

Recent work in support of the planned expansion Gordie Howe Bowl sports complex assessed the intersection of Avenue P and 11th Street with 2016 traffic volumes, and the results were very similar.

3.4 Future Conditions

3.4.1 Future Road Network

The recent report to council discussed closing the southern leg at the intersection of Avenue H and 12th Street, and the eastern leg at the intersection of Avenue I and 11th Street. This eliminates the ability for a vehicle to drive past the Water Treatment Plant on Avenue H between 11th and 12th Streets, and on 11th Street between Avenues H and I. These road closures will create an alternate route for vehicles to potentially short-cut through the King George and Holiday Park neighbourhoods.

As previously mentioned, the intersection of Avenue H and 11th Street was closed from March 2012 to November 2014. It is anticipated that the future permanent closure will be consistent with the previous closure. Accordingly the future road network is illustrated in **Exhibit 3-1**.

3.4.2 Future Intersection Geometry

The future intersection geometry will be consistent with the existing intersections geometry previously described in **Section 3.3.1**.

3.4.3 Future Traffic Volumes

As the future permanent closure will be consistent with the previous closure in place from March 2012 to November 2014, the traffic counts previously collected in February and March of 2014 are indicative of the future traffic volumes. These previous traffic counts from 2014 are summarized in **Table 3-3**.

Table 3-3: 2014 Traffic Count Information (Future Traffic Volumes)

Intersection	AM Peak Hour	PM Peak Hour
17 th Street and Avenue H	7:30 am – 8:30 am (March 4, 2014)	4:30 pm – 5:30 pm (March 4, 2014)
17 th Street and Avenue P	7:45 am – 8:45 am (March 4, 2014)	4:00 pm – 5:00 pm (March 4, 2014)
11 th Street and Avenue H	n/a	n/a
12 th Street and Avenue I	7:30 am – 8:30 am (February 25, 2014)	4:15 pm – 5:15 pm (February 25, 2014)
11 th Street and Avenue P	7:45 – 8:45 am (February 11, 2014)	4:30 pm – 5:30 pm (February 11, 2014)

The future weekday AM and PM peak hour traffic volumes are illustrated in **Exhibit 3-4**.

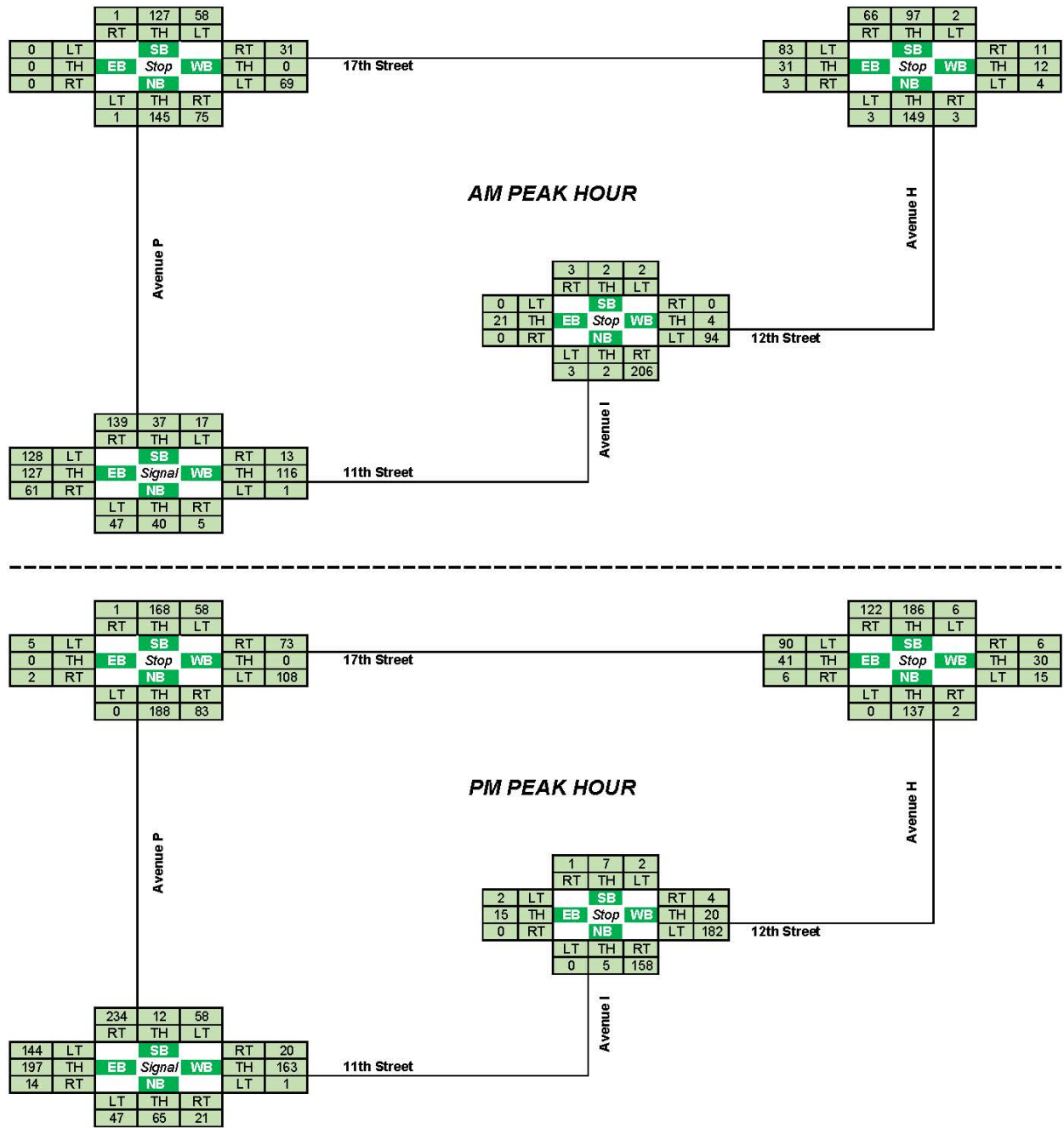

Exhibit 3-4: Future Peak Hour Traffic Volumes

3.4.4 Future Operating Conditions

Operating conditions at the studied intersections were assessed based on the existing traffic volumes shown previously in **Exhibit 3-4**. The analysis initially reflected the road network, lane configurations, and traffic controls discussed in **Section 3.4.2**. The analysis results are shown in **Table 3-4**.

Table 3-4: Future Operating Conditions

Intersection / Movement			Measures of Effectiveness								
			AM Peak Hour				PM Peak Hour				
			v/c ratio	Delay (s)	LOS	Queue (m)	v/c ratio	Delay (s)	LOS	Queue (m)	
Avenue H / 17 th Street	EB	LT/Thru	0.18	8.7	A	0	0.22	9.5	A	0	
		RT	0.00	6.4	A	0	0.01	6.8	A	0	
	WB	LT/Thru	0.02	7.5	A	0	0.07	8.2	A	0	
		RT	0.01	6.6	A	0	0.01	6.9	A	0	
	NB	LT/Thru	0.21	8.3	A	0	0.20	8.6	A	0	
		RT	0.00	6.2	A	0	0.00	6.5	A	0	
	SB	LT/Thru	0.14	7.7	A	0	0.28	9.1	A	0	
		RT	0.08	6.6	A	0	0.15	7.1	A	0	
	Intersection Summary			0.21 (max)	7.9	A	-	0.28 (max)	8.6	A	-
	Avenue P / 17 th Street	EB	LT/Thru/RT	0.00	8.6	A	0	0.01	9.1	A	0
WB		LT/Thru	0.11	8.5	A	0	0.19	9.5	A	0	
		RT	0.04	6.8	A	0	0.10	7.4	A	0	
NB		LT/Thru	0.20	8.1	A	0	0.28	9.1	A	0	
		RT	0.09	6.5	A	0	0.11	7.0	A	0	
SB		LT/Thru	0.27	8.8	A	0	0.34	10.1	B	0	
		RT	0.00	6.1	A	0	0.00	6.5	A	0	
Intersection Summary			0.27 (max)	8.1	A	-	0.34 (max)	9.1	A	-	

Table 3-4 Continued

Intersection / Movement			Measures of Effectiveness							
			AM Peak Hour				PM Peak Hour			
			v/c ratio	Delay (s)	LOS	Queue (m)	v/c ratio	Delay (s)	LOS	Queue (m)
Avenue P / 11th Street	EB	LT/Thru	0.46	14.5	B	16.4	0.52	14.1	B	20.7
		Thru/RT								
	WB	LT/Thru	0.17	13.1	B	8.2	0.21	12.4	B	10.5
		Thru/RT								
	NB	LT/Thru	0.11	5.0	A	8.7	0.14	5.9	A	11.8
		RT								
	SB	LT/Thru	0.06	4.8	A	6.1	0.10	5.7	A	8.3
RT										
Intersection Summary			0.46 (max)	10.5	B	-	0.52 (max)	10.1	B	-
Avenue I / 12th Street	EB	LT/Thru/RT	0.00	0.0	A	0	0.00	0.8	A	0
	WB	LT/Thru/RT	0.06	7.1	A	0	0.11	6.7	A	0
	NB	LT/Thru/RT	0.20	9.3	A	0	0.16	9.3	A	0
	SB	LT/Thru/RT	0.01	10.6	B	0	0.02	13.4	B	0
	Intersection Summary			0.20 (max)	8.1	A	-	0.16 (max)	7.7	A

As illustrated in **Table 3-4**, all intersection movements are operating at an overall LOS of B or better and with a v/c ratio of 0.52 or less during the AM and PM peak hours.

A review of the analysis results yields the following conclusions:

- No intersection improvements will be required when the road closures are placed.
- The current infrastructure can satisfactorily accommodate the change in traffic patterns that will result with the road closures.

3.5 Cut-Through Traffic Mitigation

Comparing the existing traffic volumes with the expected traffic volumes once the roads are closed adjacent to the water treatment plant, it is evident that a direct impact will be increased traffic on the segments of 12th Street and Avenue I immediately adjacent to the water treatment plant.

It is expected that the road closures themselves will provide an overall benefit to the neighbourhoods of King George and Holiday Park by reducing through traffic. At the intersection of 17th Street and Avenue H, a review of the two sets of traffic count information is summarized in **Table 3-5**.

Table 3-5: Traffic Count Review

Direction		Movement	AM Peak Hour		PM Peak Hour	
			Existing	Future	Existing	Future
Represents traffic from the west	EB	LT	70%	71%	49%	66%
		Thru	30%	26%	46%	30%
		RT	0%	3%	5%	4%
Represents traffic from the north	SB	LT	0%	1%	4%	1%
		Thru	65%	59%	76%	59%
		RT	35%	40%	20%	39%

A review of the information in the above table yields the following information:

- The traffic in the AM peak hour is not affected by the road closures.
- In the PM peak hour the eastbound left-turn increases from 49% to 66% indicating that the road closure will re-assign traffic to 17th Street and away from 11th Street through the King George and Holiday Park neighbourhoods.
- In the AM peak hour the southbound through movements decreases from 76% to 59%, and the southbound right-turn increases from 20% to 39%. This indicates that the road closure will re-assign traffic to 17th Street and away from Avenue H.

There are three other traffic calming measures recommended to further encourage drivers to use 17th Street and Avenue P, instead of 11th Street and Avenue H through the residential areas:

- Installation of a guide sign on the southbound approach to the intersection of 17th Street and Avenue H indicating turn right to access 'Circle Drive South'.
- Installation of traffic calming devices such as a curb extension at the intersection of 16th Street and Avenue H, and a centre median at the intersection of 15th Street and Avenue H.
- Revision of the traffic signals at the intersection of 11th Street and Avenue P to promote the eastbound left-turn movement from 11th Street onto Avenue P. This can be achieved through the addition of a dedicated left-turn arrow for the eastbound approach. Adding a dedicated left-turn arrow will require geometric modifications to the intersection on the eastern leg to physically restrict the eastbound through movement.

The following conclusions can be drawn:

1. No immediate intersection improvements are required.
2. No intersection improvements will be required when the road closures are instituted.
3. The current infrastructure can satisfactorily accommodate the change in traffic patterns that will result with the road closures.
4. Traffic will increase on segments of 12th Street and Avenue I immediately adjacent to the water treatment plant. However, there are mitigation measures available to reduce the impact.

The following recommendations are provided:

1. The road closures should proceed prior to the 17th Street Extension being completed.
2. Install the following mitigation measures to reduce cut-through traffic and calm traffic:
 - Installation of a guide sign on the southbound approach to the intersection of 17th Street and Avenue H indicating turn right to access 'Circle Drive South'.
 - Installation of traffic calming devices such as a curb extension at the intersection of 16th Street and Avenue H, and a centre median at the intersection of 15th Street and Avenue H.
 - Revise the traffic signals at the intersection of 11th Street and Avenue P to promote the eastbound left turn movement from 11th Street onto Avenue P. This can be achieved through the addition of a dedicated left-turn arrow for the eastbound approach. Adding a dedicated left-turn arrow will require geometric modifications to the intersection on the eastern leg to physically restrict the eastbound through movement.

Functional plans of the recommended changes are provided in **Appendix C**.

4 17TH STREET EXTENSION

4.1 Background

The 17th Street extension project was identified in the *West Industrial Concept Plan*, which was approved by City Council on May 20, 2008 and is included as **Exhibit 4-1**. The concept plan identified extending 17th Street from the intersection of 11th Street and Avenue P extending west to 11th Street. This extension would provide an attractive alternative route through the sector, and a more direct connection between the City Centre and Circle Drive. This connection may reduce short-cutting traffic along 11th Street and Avenue H through the King George and Holiday Park neighbourhoods by providing a more direct, higher capacity roadway. The extension of 17th Street would be an arterial roadway constructed on abandoned Canadian National right-of-way that was acquired by the City of Saskatoon in 2002.

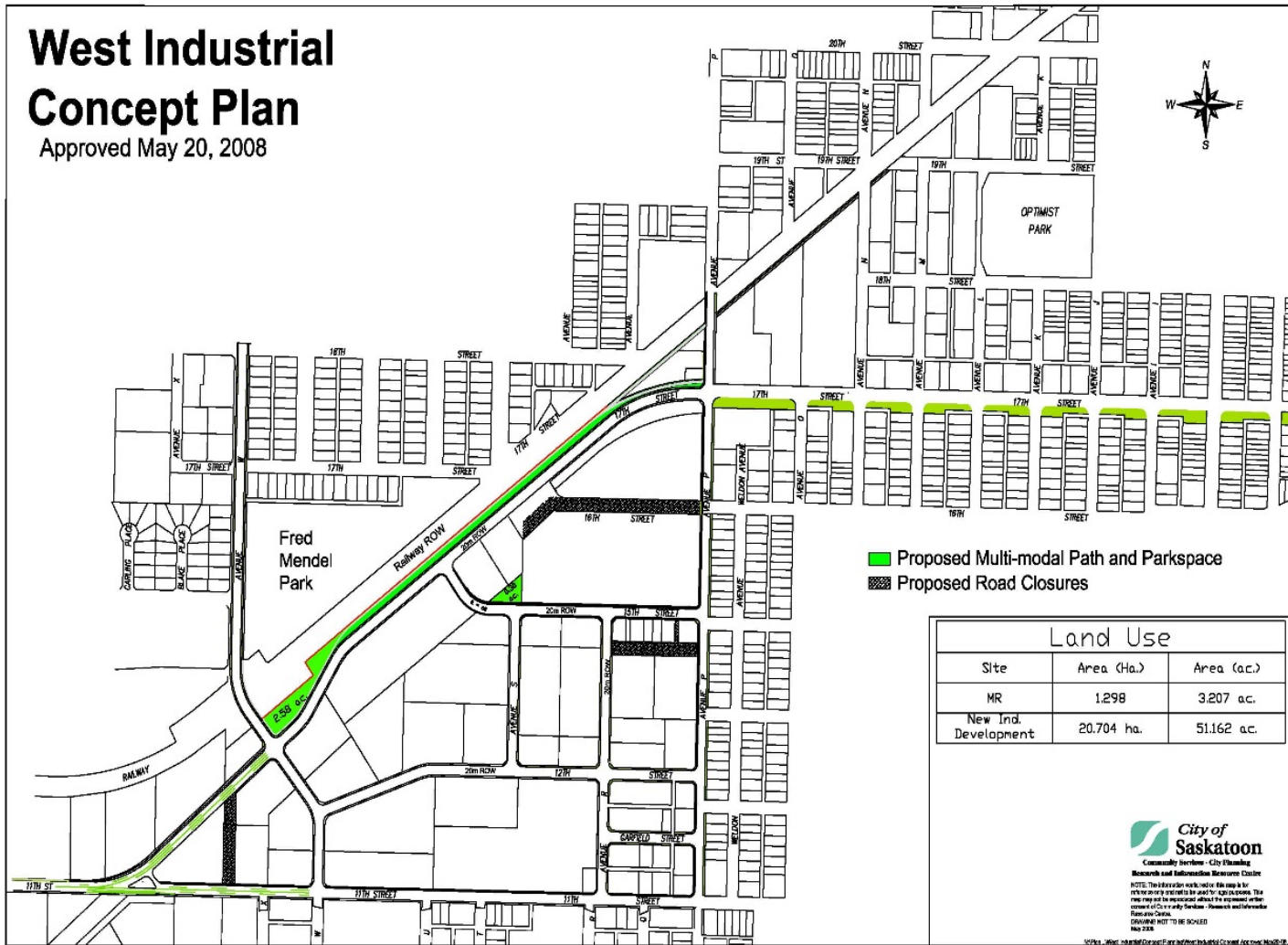

Exhibit 4-1: West Industrial Concept Plan

4.2 Existing Conditions

17th Street is currently aligned east-west with a cross-section that includes one driving lane and one parking lane in each direction. It begins at Avenue P to the west and terminates at the Spadina Crescent. Between Avenue P and Avenue H the street is classified as a minor arterial and has industrial land use immediately adjacent to the north, with the exception of one parcel of multi-family housing. Immediately south is a multi-use pathway and a wider right-of-way that provides a buffer between the street and the single family housing residential land use to the south.

4.3 Future Land Use

The West Industrial Concept Plan does not envision changing the land use, where assigned industrial, to another use. It is expected that the existing industrial parcels will remain industrial, and that the vacant parcels zoned industrial, will eventually be developed in accordance with the current zoning.

4.4 Future Traffic Volumes

The Saskatoon Region Travel Demand Model, developed in partnership with the Saskatchewan Ministry of Highways & Infrastructure (MHI), was used to provide traffic projections. For planning purposes a population horizon of 400,000, and the accompanying traffic projections for this horizon were used. The future AM and PM weekday peak hour traffic volumes are provided in **Exhibit 4-2**. The forecast daily traffic on the 17th Street extension is 11,000 vehicles per day.

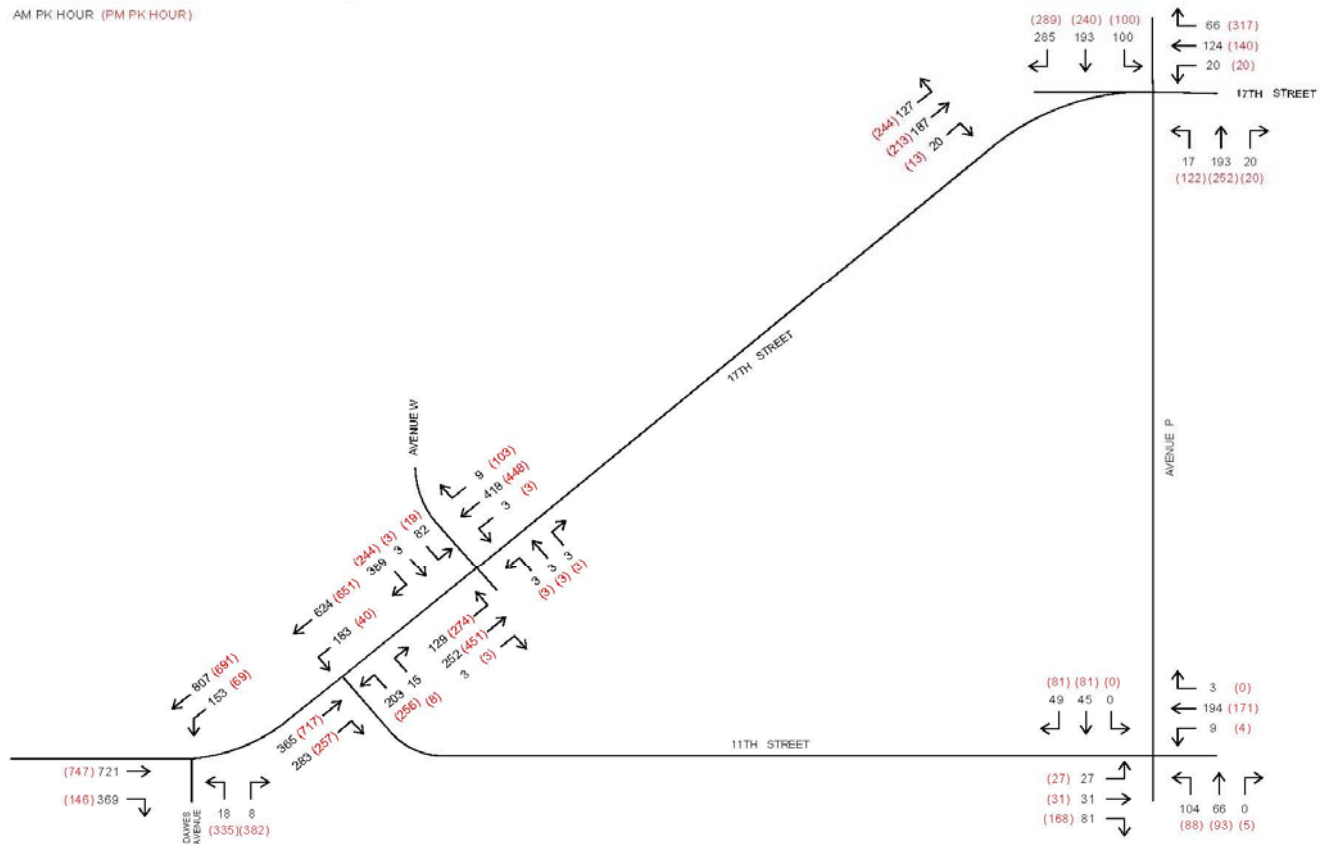

Exhibit 4-2: Future Traffic Volumes

4.5 Future Traffic Analysis

The analysis assumed the following:

- The road network as per the West Industrial Concept Plan.
- The design in accordance with the design criteria.
- The 17th Street extension will intersect 11th Street W at the transition to an urban four lane major arterial street just east of Dawes Avenue
- The intersection of 17th Street and Avenue P will be signalized on opening day.
- The intersection of 17th Street and Avenue W will be signalized on opening day.
- The intersection of 17th Street and 11th Street will be signalized on opening day.

Operating conditions at the studied intersections were assessed based on the future traffic volumes shown previously in **Exhibit 4-2**. The analysis results are shown in **Table 4-1**.

Table 4-1: Future Operating Conditions

Intersection / Movement			Measures of Effectiveness							
			AM Peak Hour				PM Peak Hour			
			v/c ratio	Delay (s)	LOS	Queue (m)	v/c ratio	Delay (s)	LOS	Queue (m)
Ave P / 17 th Street	EB	LT	0.48	29.0	C	34	0.93	59.0	E	76
		Thru	0.35	27.0	C	48	0.29	18.0	B	43
		RT	0.04	9.0	A	6	0.02	6.0	A	3
	WB	LT/Thru/RT	0.73	47.0	D	63	0.96	57.0	E	140
	NB	LT/Thru/RT	0.24	47.0	B	38	0.82	37.0	D	124
	SB	LT/Thru/RT	0.66	16.0	B	119	0.94	44.0	D	185
	Intersection Summary		0.73 (max)	23.0	D	-	0.96 (max)	44.0	D	-
Ave W / 17 th Street	EB	LT	0.40	19.0	B	23	0.59	28.0	C	45
		Thru/RT	0.23	18.0	B	24	0.29	10.0	A	19
	WB	LT	0.01	13.0	B	2	0.01	9.0	A	2
		Thru/RT	0.66	32.0	C	46	0.72	30.0	C	54
	NB	LT/Thru/RT	0.01	10.0	A	3	0.01	16.0	B	4
	SB	LT/Thru	0.12	12.0	B	17	0.04	18.0	B	8
		RT	0.41	4.0	A	21	0.34	5.0	A	16
Intersection Summary		0.66 (max)	18.0	B	-	0.72 (max)	20.0	A	-	
11 th Street / 17 th Street	WB	LT	0.29	13.0	B	31	0.32	15.0	B	48
		RT	0.02	7.0	A	A	0.01	8.0	A	4
	NB	LT/Thru/RT	0.46	6.0	A	18	0.75	27.0	C	65
	SB	LT	0.84	44.0	D	42	0.43	41.0	D	10
		Thru/RT	0.47	12.0	B	27	0.50	32.0	C	52
	Intersection Summary		0.84 (max)	13.0	A	-	0.75 (max)	27.0	C	-

As illustrated in **Table 4-1**, all intersection movements are operating at an overall LOS of D or better during the AM and PM peak hours.

4.6 Design Criteria

The design criteria established for preparing the functional plans for the 17th Street extension are summarized in **Table 4-2**.

Table 4-2: Design Criteria

Criteria	Specification
Design Speed	<ul style="list-style-type: none"> • 50 kilometre per hour (kph)
Classification	<ul style="list-style-type: none"> • Arterial 'B'
Sidewalks / Pathways	<ul style="list-style-type: none"> • 17th Street: 3.0 metre (m) multi-use pathway on north side; 1.8 m concrete sidewalk on south side • Avenue W: 1.8 m concrete sidewalks on both sides
Cross Section	<ul style="list-style-type: none"> • Vertical Curb and Gutter
Corner Radius	<ul style="list-style-type: none"> • 15 m (industrial land use)
Design Traffic Volume	<ul style="list-style-type: none"> • 5,000 – 30,000 vehicles per day

Other design considerations included the inclusion of active transportation facilities in accordance with the *Active Transportation Plan*.

The resultant 17th Street extension plan is illustrated in **Exhibit 4-3**.



Exhibit 4-3: 17th Street Extension Plan

4.7 Functional Plans

All drawings and plans referenced in this section are included in **Appendix D**. The functional designs developed were modified where appropriate from City of Saskatoon design standards based on road classification, traffic operation, and storage length analysis.

Highlights from the recommended functional plans include:

- Pedestrian facilities on both sides of the street to facilitate connections between the pathway west on 11th Street and the pathway east on 17th Street.
- A multi-use (shared-use) pathway on the north side of the street, and a concrete sidewalk on the south side of 17th Street to encourage development along the street.
- The small segment of Avenue W that is deflected to facilitate the connection to 17th Street is shown with sidewalks to complete the pedestrian network in the area.
- Access and egress for the Suncor site would be via a new intersection on 17th Street opposite Avenue W. This would enable the closure of the existing 11th Street egress near the Cameco office building. When meeting with Cameco they highlighted a potential issue of the oil trucks leaving the Suncor site, and if there was an accident their employees would be in close proximity. Relocating the egress to the new intersection of 17th Street and Avenue W would increase the level the safety for Cameco employees.

5 OTHER ISSUES

5.1 Sidewalks

The issue of lack of sidewalks along 11th Street between Avenue P and Avenue W was identified by residents through the public engagement component of this project. It is recommended that sidewalks are installed along this segment of 11th Street but the feasibility of doing so requires assessment. There are a number of large mature trees on both public right-of-way and private property, utility poles, and private fencing. It may not be possible to install sidewalks without removing large mature trees. This issue is highlighted in **Exhibit 5-1**.



Source: Google Streetview

Exhibit 5-1: 11th Street Looking West

Missing sidewalks with the neighbourhoods of Holiday Park and King George will be addressed through the Active Transportation Plan and the Neighbourhood Traffic Review program. Both neighbourhoods should have a neighbourhood traffic reviews completed in the next few years.

5.2 17th Street Traffic Calming

The issue of speeding on 17th Street between Avenue H and Avenue P was identified as a concern by residents through the public engagement component of this project. The 85th percentile speed, which is the speed at which 85 percent of vehicles are travelling at or below, was measured for this segment of 17th Street and determined to be 52 kph. It is concluded that there is not a speeding issue on 17th Street, however to assist in pedestrian crossing safety, with the added benefit of reducing speeds, traffic calming measures such as raised median islands are recommended for the Avenue J and Avenue L intersections with 17th Street. Functional plans for these measures are included in **Appendix E**.

5.3 17th Street and Avenue P Intersection

17th Street is aligned east-west with a cross section that includes one driving lane and one parking lane in each direction. 17th Street is classified as a local street with a posted speed of 50 kph. Avenue P is aligned north to south with a cross section that includes one driving lane and one parking lane in each direction. Avenue P is classified as a minor arterial with a posted speed of 50 kph. The existing traffic control device at the intersection of 17th Street and Avenue P is a three-way stop. Through the course of the public engagement there were no major concerns identified at this intersection.

Traffic and pedestrian counts were collected at this intersection in July 2016 during the weekday peak hours (7:00 a.m to 9:00 a.m; 11:30 a.m to 1:30 p.m; 3:00 p.m to 6:00 p.m). The counts were used to analyse the current and future traffic control at this intersection.

Operating conditions at the studied intersections were assessed based on the existing traffic volumes. The analysis results are shown in **Table 5-1**.

Table 5-1: 17th Street and Avenue P Intersection Operating Conditions

Intersection / Movement			Measures of Effectiveness							
			AM Peak Hour				PM Peak Hour			
			v/c ratio	Delay (s)	LOS	Queue (m)	v/c ratio	Delay (s)	LOS	Queue (m)
Ave P / 17 th Street	EB	LT/Thru/RT	0.00	7.8	A	-	0.01	8.5	A	-
	WB	LT/Thru/RT	0.10	8.3	A	-	0.23	9.5	A	-
	NB	LT/Thru/RT	0.25	8.7	A	-	0.33	9.9	A	-
	SB	LT/Thru/RT	0.25	8.8	A	-	0.36	10.4	B	-
	Intersection Summary		0.25 (max)	8.7	A	-	0.36 (max)	10.0	A	-

As illustrated in **Table 5-1**, all intersection movements are operating at an overall LOS of A or better during the AM and PM peak hours.

The most recent available five-year collision data from SGI is from 2012 to 2016. This data was reviewed for collision configuration at the intersection of 17th Street and Avenue P. This data is presented in **Table 5-2** below:

Table 5-2: 17th Street and Avenue P Intersection Collisions Statistics

Year	Number of Collisions	Type of Collision			
		Left Turn	Right Angle	Rear End	Other
2012	2	0	0	1	1
2013	3	0	0	1	2
2014	2	0	0	0	2
2015	2	0	0	2	0
2016	4	1	0	2	1

The following was noted based on the collision table above:

- Approximately 46% of the collisions at this intersection are rear-end collisions.
- No fatalities were noted over the period 2012 – 2016.

Based on this traffic analysis, it is recommended that no changes should occur at this location until 17th Street is extended to 11th Street (17th Street extension).

5.4 17th Street and Avenue H Intersection

17th Street is aligned east to west with a cross section that includes one driving lane and one parking lane in each direction. 17th Street is classified as a local speed with a posted speed of 50 kph. Avenue H is classified as a minor arterial road with a posted speed of 50 kph. Avenue H is aligned north to south with a cross section that includes one driving lane and one parking lane in each direction. The existing traffic control device at the intersection of 11th Street and Avenue H is a four-way stop. Previous studies at this intersection indicated that a traffic signal was not warranted at the intersection. Through the course of the public engagement there were no major concerns identified at this intersection.

Traffic and pedestrian counts were collected at this intersection in January 2016 during the weekday peak hours (7:00 a.m to 9:00 a.m; 11:30 a.m to 1:30 p.m; 3:00 p.m to 6:00 p.m). The counts were used to analyze the current and future traffic control at this intersection.

Operating conditions at the studied intersections were assessed based on the existing traffic volumes. The analysis results are shown in **Table 5-3**.

Table 5-3: 17th Street and Avenue H Intersection Operating Conditions

Intersection / Movement			Measures of Effectiveness							
			AM Peak Hour				PM Peak Hour			
			v/c ratio	Delay (s)	LOS	Queue (m)	v/c ratio	Delay (s)	LOS	Queue (m)
Ave H / 17 th Street	EB	LT/Thru/RT	0.10	8.2	A	-	0.16	9.4	A	-
	WB	LT/Thru/RT	0.03	7.7	A	-	0.08	8.8	A	-
	NB	LT/Thru/RT	0.16	8.1	A	-	0.28	9.6	A	-
	SB	LT/Thru/RT	0.16	7.9	A	-	0.41	10.6	B	-
	Intersection Summary		0.16 (max)	8.0	A	-	0.41 (max)	10.0	A	-

As illustrated in **Table 5-3**, all intersection movements are operating at an overall LOS of A or better during the AM and PM peak hours.

The most recent available five-year collision data from SGI is from 2012 to 2016. This data was reviewed for collision configuration at the intersection of 17th Street and Avenue P. This data is presented in **Table 5-2** below:

Table 5-4: 17th Street and Avenue H Intersection Collisions Statistics

Year	Number of Collisions	Type of Collision			
		Left Turn	Right Angle	Rear End	Other
2012	6	2	2	0	4
2013	3	0	2	0	1
2014	2	0	0	2	0
2015	2	0	1	1	0
2016	2	0	1	1	0

The following was noted based on the collision table above:

- Approximately 40% of the collisions at this intersection are right-angle collisions.
- No fatalities were noted over the period 2012 – 2016.

Based on the analysis, it is recommended that no changes should occur at this location. Traffic conditions should be reviewed after 17th Street is extended to 11th Street (17th Street extension). A guide sign should be installed on the southbound approach at this intersection indicating turn right to access “Circle Drive South”.

6 RECOMMENDATIONS, COST ESTIMATES AND TIMEFRAMES

After a comprehensive study of the southwest area of the City, the following recommendations, cost estimates, and timeframes are provided in **Table 6-1**.

Table 6-1: Recommendations, Cost Estimates and Timeframes

Location	Recommendation	Justification	Cost Estimate	Timeframe
11 th Street & Avenue W (west intersection)	Installing a traffic signal; major intersection improvement	Reduce delays and improve the efficiency of the intersection	\$182,000	2 - 5 years
11 th Street & Avenue P	Geometric modifications on the east leg; install an eastbound left turn signal arrow	Reduce eastbound through movement to a single lane; mitigate cut through traffic; improve the efficiency of the intersection	\$10,000	0 - 2 years
11 th Street & Avenue H	Permanent Closure at 11 th Street & Avenue I (east leg); permanent closure at 12 th Street & Avenue H (South leg)	To fully enclose the Water Treatment Plant	\$3,000	0 - 2 years
Avenue H & 15 th Street	Install a raised median island on Avenue H	Improve pedestrian safety and reduce short-cutting traffic	\$3,000	0 - 2 years
Avenue H & 16 th Street	Install curb extensions	Improve pedestrian safety and reduce short-cutting traffic	\$10,000	0 - 2 years
17 th Street & Avenue H	Install guide sign on the southbound approach indicating to turn right to access Circle Drive South	Reduce short-cutting traffic along Avenue H and direct traffic to use a more direct and higher capacity roadway	\$1,000	0 - 2 years

Table 6-1 Continued

Location	Recommendation	Justification	Cost Estimate	Timeframe
17th Street & Avenue J	Install a raised median island on 17th Street	Improve pedestrian safety and reduce speeding	\$3,000	0 - 2 years
17th Street & Avenue L	Install a raised median island on 17th Street	Improve pedestrian safety and reduce speeding	\$3,000	0 - 2 years
17 th Street Extension	Modifications to the transportation network	Reduce short-cutting along 11 th Street and Avenue H by providing a more direct and higher capacity roadway	\$9,000,000 - \$11,000,000	5 - 10 years
11 th Street (Avenue W - Avenue P)	Construct sidewalks on 11 th Street (Ave W - Ave P)	Provide a better pedestrian connection	\$550,000	0 - 5 years

Appendix A

Traffic Analysis Methodology

Traffic analysis for the weekday AM and PM peak hours operating conditions at the identified intersections was carried out using the Synchro / SimTraffic software package. Synchro / SimTraffic software is based upon the methodology outlined in the Highway Capacity Manual (HCM).

In the HCM methodology, Level-Of-Service (LOS) is the primary evaluation criteria for operating conditions. For unsignalized intersections, the LOS is based on the computed delays, LOS 'A' represents minimal delays to minor street traffic movements, and LOS 'F' represents a scenario with an insufficient number of gaps on the major street for minor street motorists to complete their movements without significant delays. For signalized intersections, the methodology considers the intersection geometry, traffic volumes and composition, traffic signal / timing plan, and pedestrian volumes. The average delay for each lane group is calculated, as well as the average delay for the overall intersection.

Also, for signalized intersection, the 'volume to capacity' (v/c) ratio is used as an indicator of the extent to which a particular movement capacity is being utilized.

The HCM intersection capacity evaluation criteria for both unsignalized and signalized intersections are summarized in the table below.

Table: Level of Service Standards

Level of Service (LOS)	Average Delay for UNSIGNALIZED intersection Movements	Average Delay for SIGNALIZED intersection Movements
A	0 – 10 sec. per vehicle	0 – 10 sec. per vehicle
B	> 10 – 15 sec. per vehicle	> 10 – 15 sec. per vehicle
C	> 15 – 25 sec. per vehicle	> 15 – 25 sec. per vehicle
D	> 25 – 35 sec. per vehicle	> 25 – 35 sec. per vehicle
E	> 35 – 50 sec. per vehicle	> 35 – 50 sec. per vehicle
F	> 50 sec. per vehicle	> 50 sec. per vehicle

Typically, an individual intersection movement of LOS E or worse is an indication that intersection improvements such as traffic signals, additional lanes, and so on may be required.

Appendix B

Functional Plan of Near-Term Improvements for 11th Street and Avenue W West Intersection

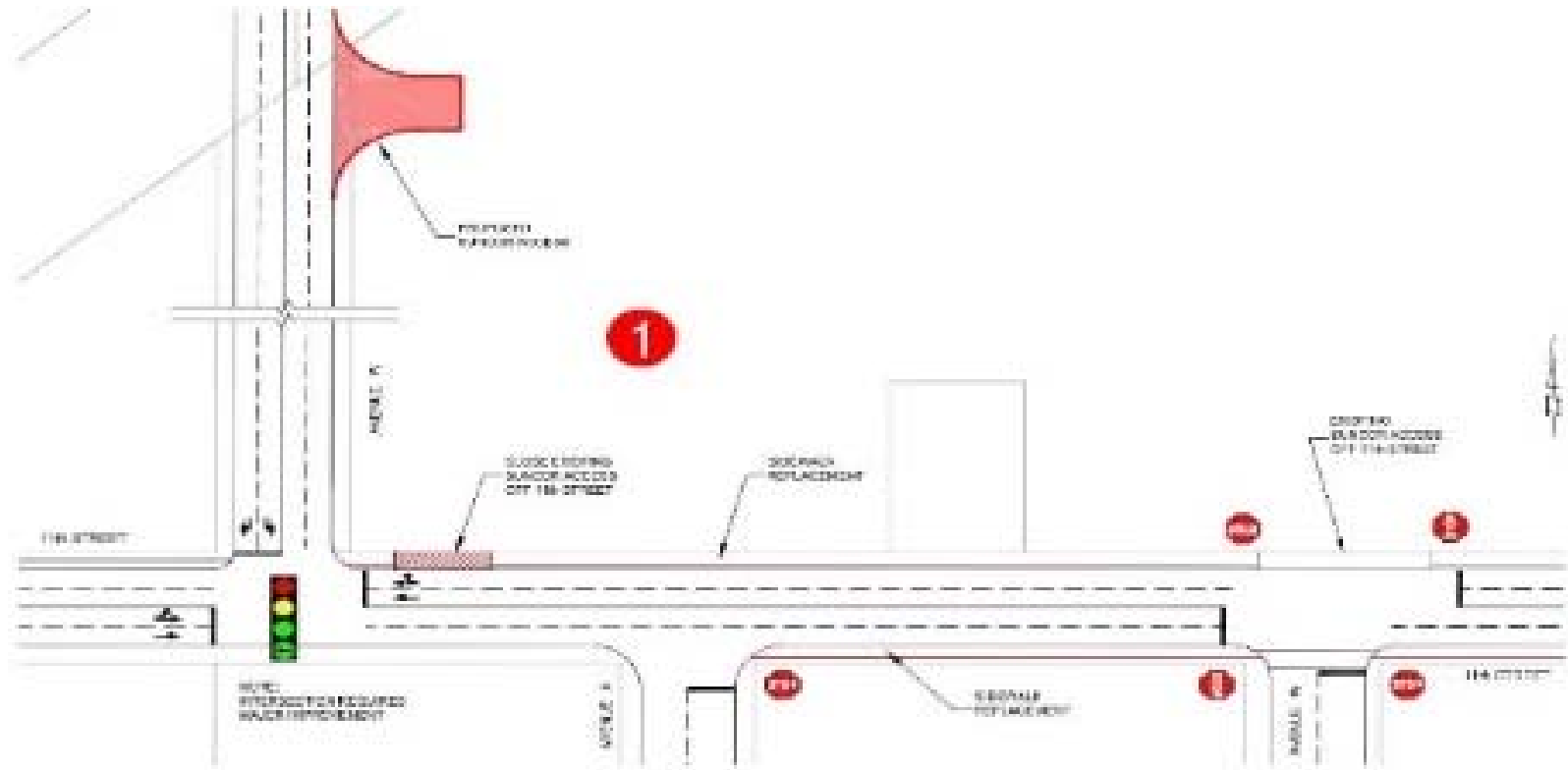

Appendix C

Functional Plan of Near-Term Improvements Required to Support Water Treatment Plant Road Closures

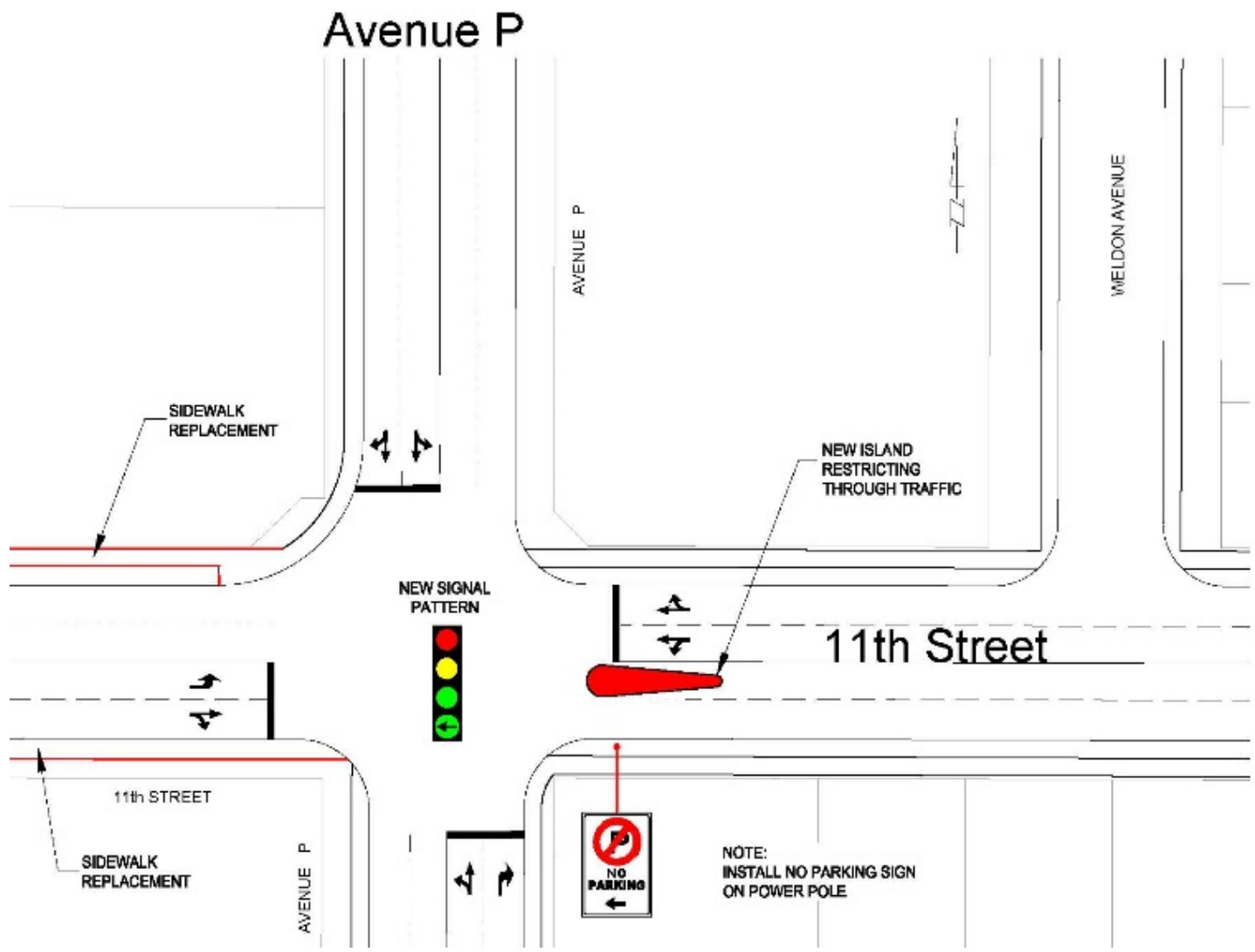

Intersection of Avenue P and 11th Street

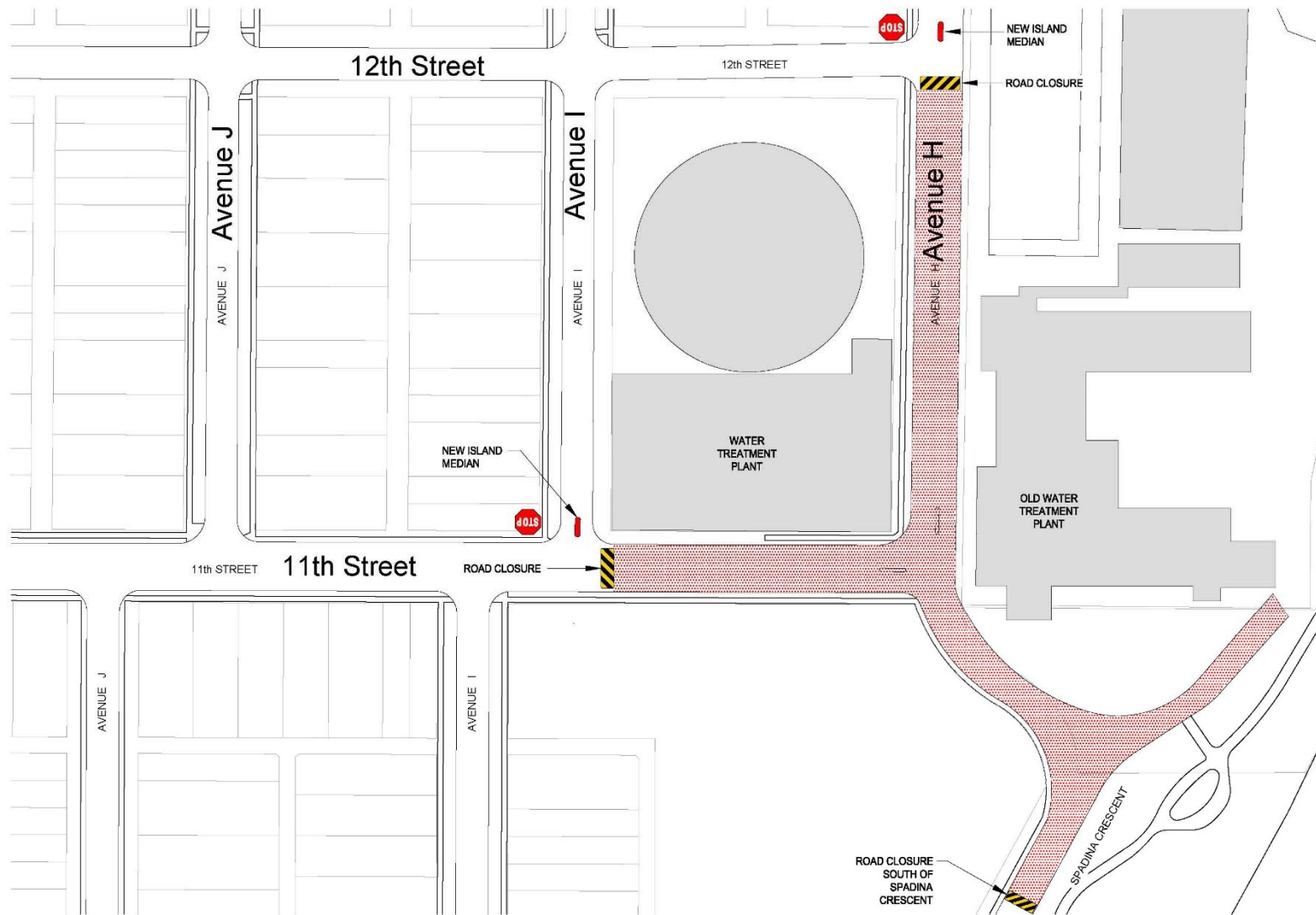

Avenue H and 11th Street Road Closures

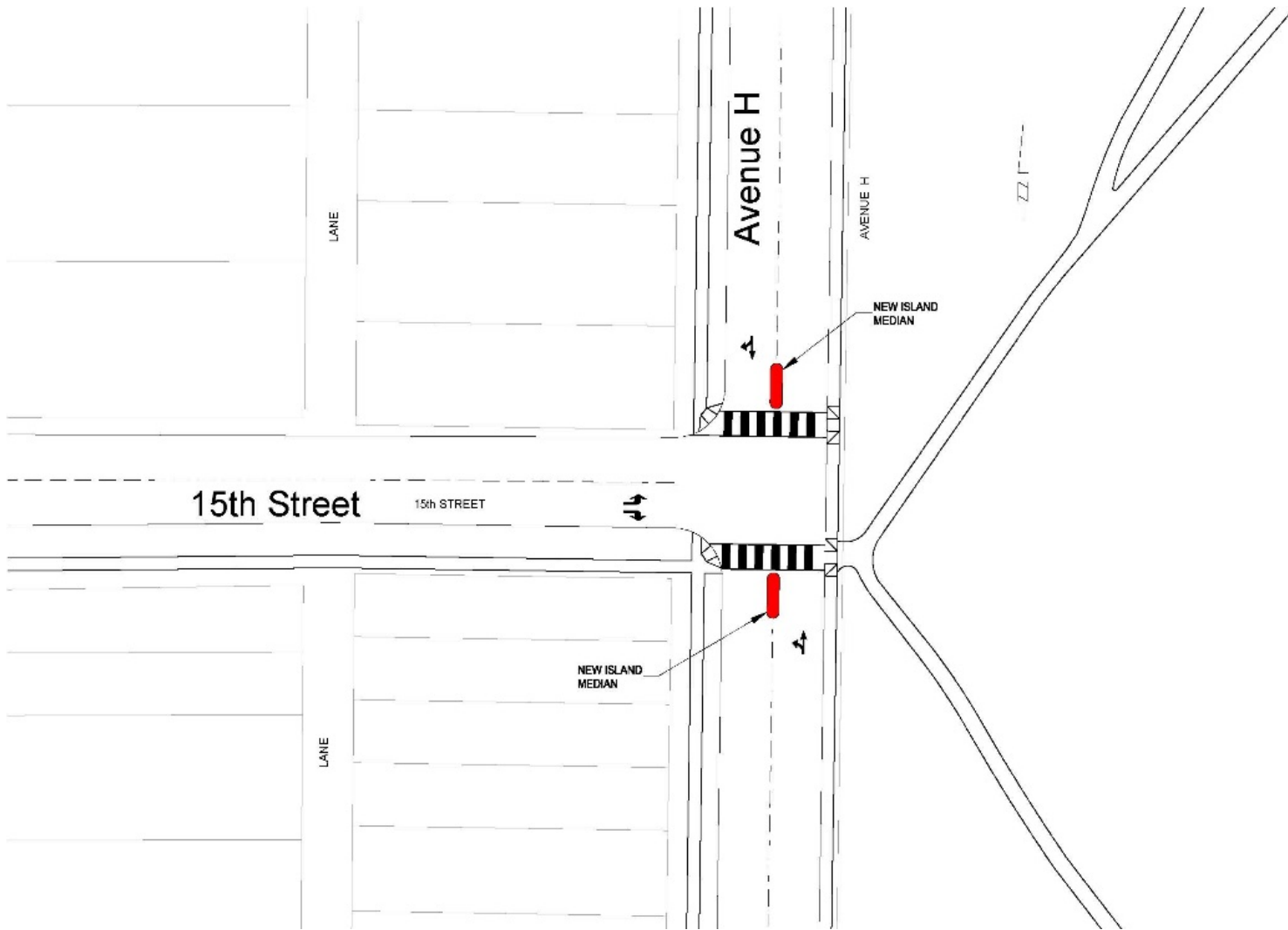

Avenue H and 15th Street Traffic Calming

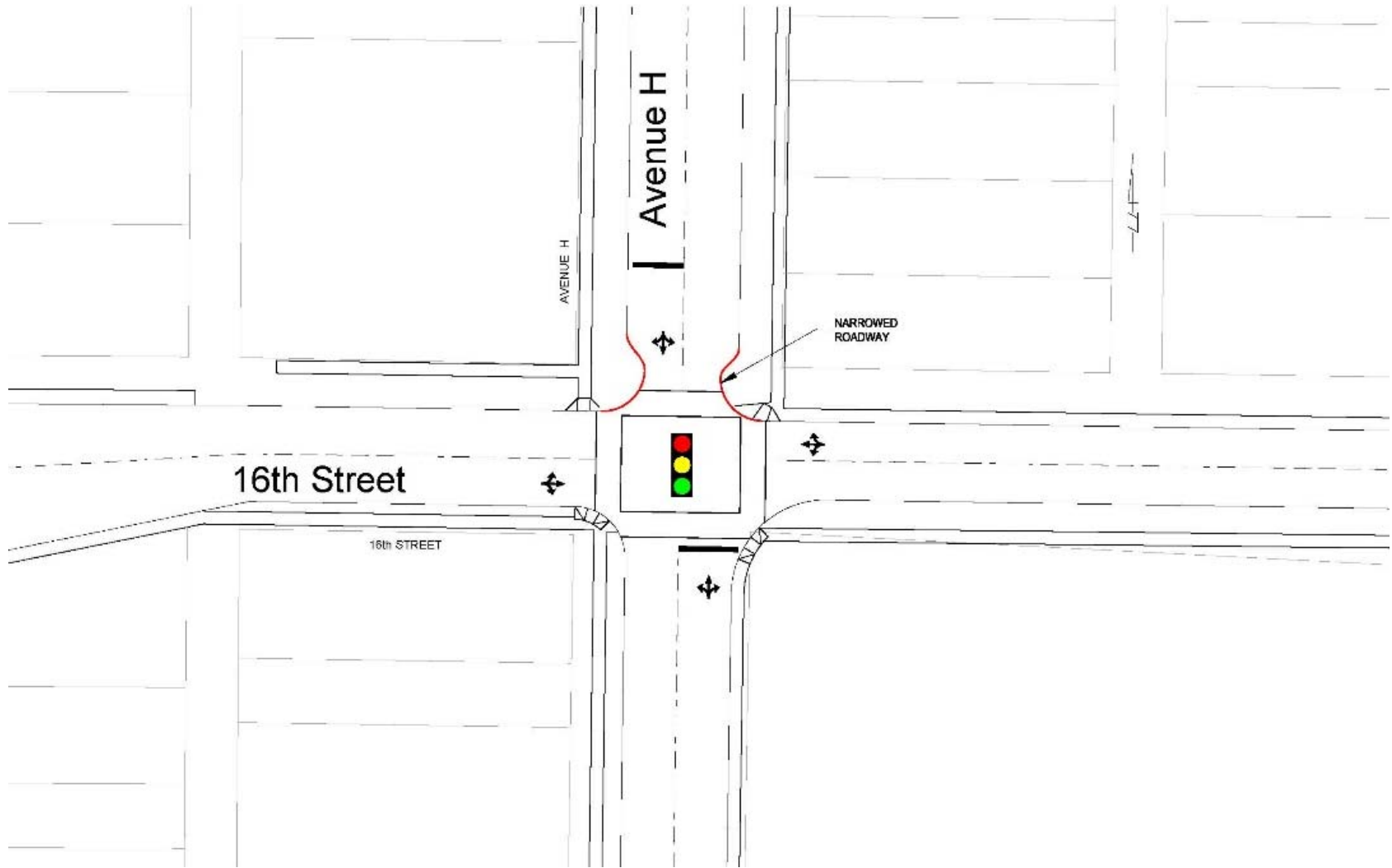

Avenue H and 16th Street Traffic Calming



Avenue H and 17th Street Traffic Calming

Appendix D

Functional Plan of 17th Street Extension

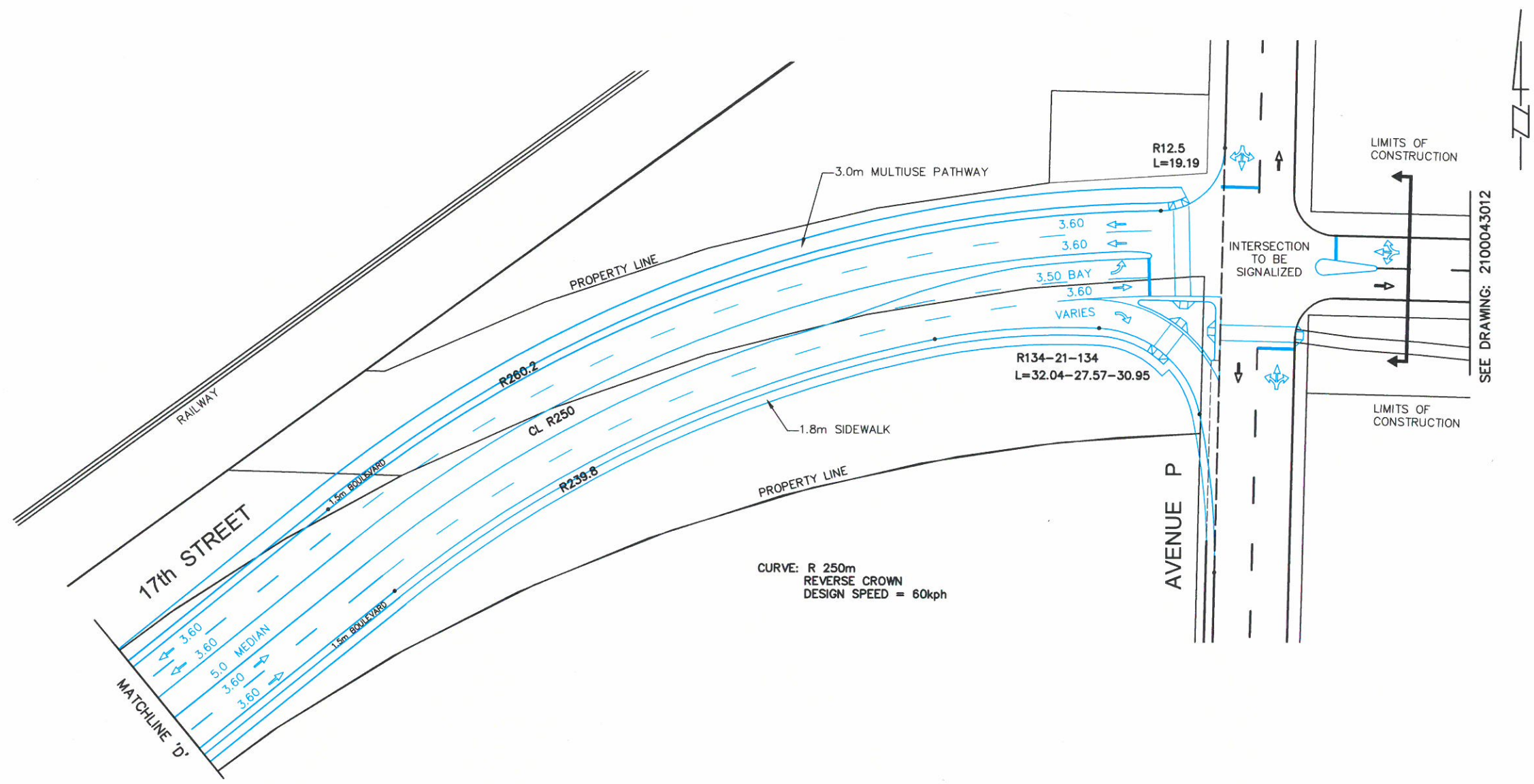

LEGEND

EXISTING CONDITIONS = BLACK
 REVISED 4 LANE CROSS SECTION = BLUE

LANE WIDTH LABELLING

LANE WIDTH LABELLING IS EXCLUSIVE OF GUTTER AND OFFSET DIMENSIONS

FUNCTIONAL

PROJECT NO. 75492

TRANSPORTATION DIVISION - FUNCTIONAL	
ENGINEER	DATE
ENGINEER	28.12.2018
ENGINEER	DATE
ENGINEER	DATE
DRAWN BY: AMR	DATE: 2018-JUN-04



FUNCTIONAL INTERSECTION MODIFICATION

SOUTH WEST TRANSPORTATION STUDY
 17th STREET EAST - 870m EAST OF 11th STREET TO AVENUE P
 FUNCTIONAL PLAN

DIRECTOR	<i>[Signature]</i>
SCALES:	
HOR:	1:1000
VERT:	
SHEET NO.	1 OF 8
PLAN NO.	249-0043-001r001
DATE	Mar. 5 / 18

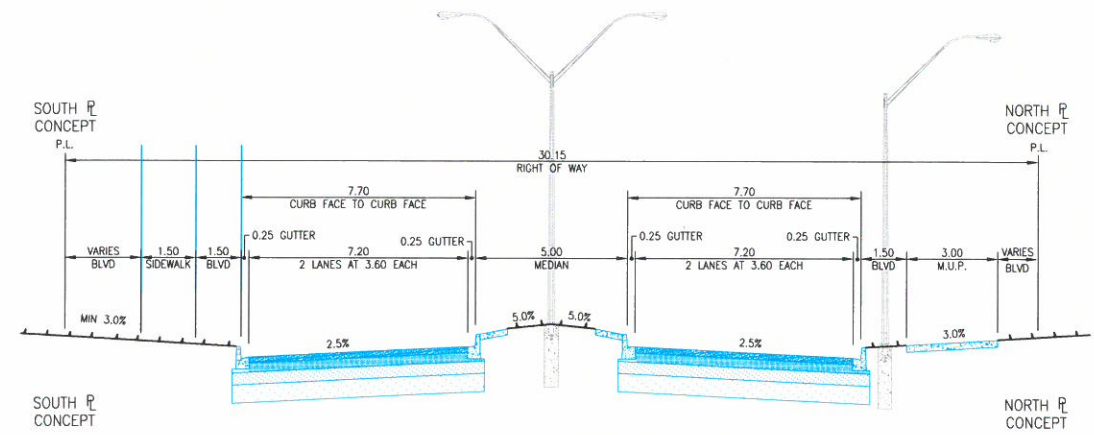
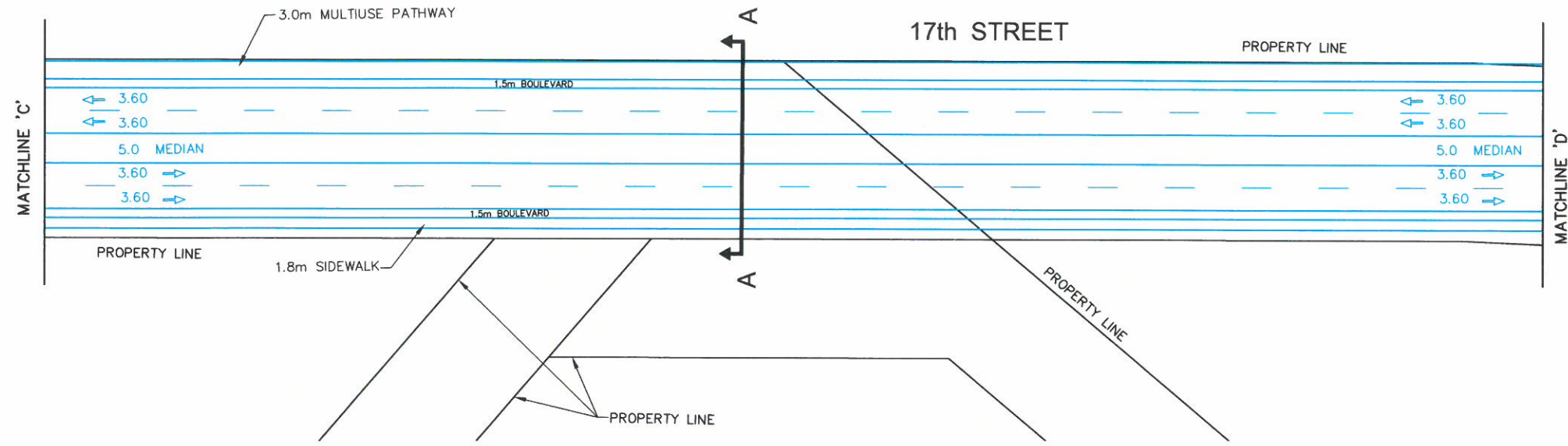

CROSS SECTION A-A

LEGEND
 EXISTING CONDITIONS = BLACK
 REVISED 4 LANE CROSS SECTION = BLUE

LANE WIDTH LABELLING
 LANE WIDTH LABELLING IS EXCLUSIVE OF GUTTER
 AND OFFSET DIMENSIONS

FUNCTIONAL
 PROJECT NO. 75492

TRANSPORTATION DIVISION - FUNCTIONAL	
ENGINEER	DATE
ENGINEER	DATE 2018-01-04
ENGINEER	DATE
ENGINEER	DATE
ENGINEER	DATE
DRAWN BY AMR	DATE 2018-JAN-04



FUNCTIONAL INTERSECTION MODIFICATION
 SOUTH WEST TRANSPORTATION STUDY
 17th STREET EAST - 610m EAST OF 11th STREET TO 870m EAST
 FUNCTIONAL PLAN

DIRECTOR	DATE Mar. 5/18
SCALES	1:1000
HOR.	
VERT.	
SHEET NO. 2 OF 8	PLAN NO. 249-0043-001r001

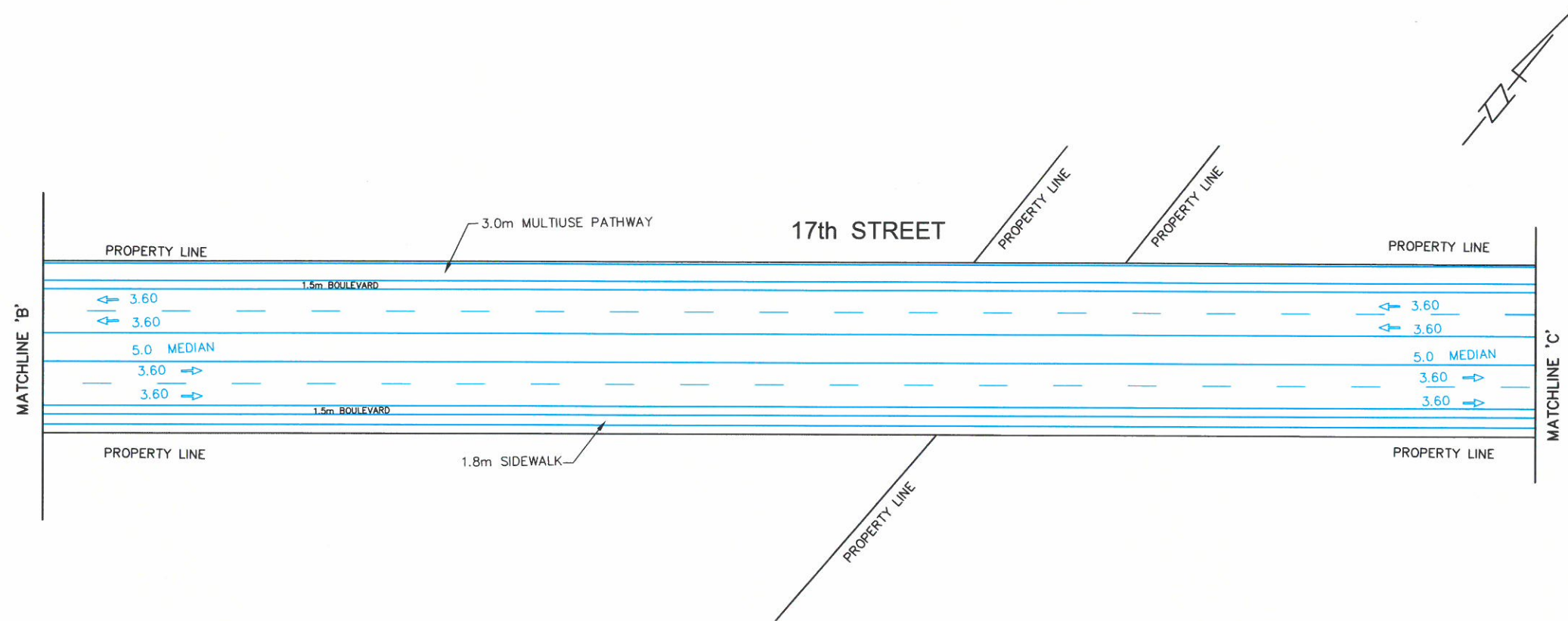

LEGEND

EXISTING CONDITIONS = BLACK
 REVISED 4 LANE CROSS SECTION = BLUE

LANE WIDTH LABELLING

LANE WIDTH LABELLING IS EXCLUSIVE OF GUTTER AND OFFSET DIMENSIONS

FUNCTIONAL

PROJECT NO. 75492

TRANSPORTATION DIVISION - FUNCTIONAL	
ENGINEER	DATE
ENGINEER	DATE
ENGINEER	DATE
ENGINEER	DATE
DRAWN BY: AMR	DATE: 2018-JAN-04



FUNCTIONAL INTERSECTION MODIFICATION

SOUTH WEST TRANSPORTATION STUDY

17th STREET EAST - 350m EAST OF 11th STREET TO 610m EAST

FUNCTIONAL PLAN

DIRECTOR	
SCALES:	
HOR.	1:1000
VERT.	
SHEET NO.	3 OF 8
PLAN NO.	249-0043-001r001
DATE	Mar 5 / 18

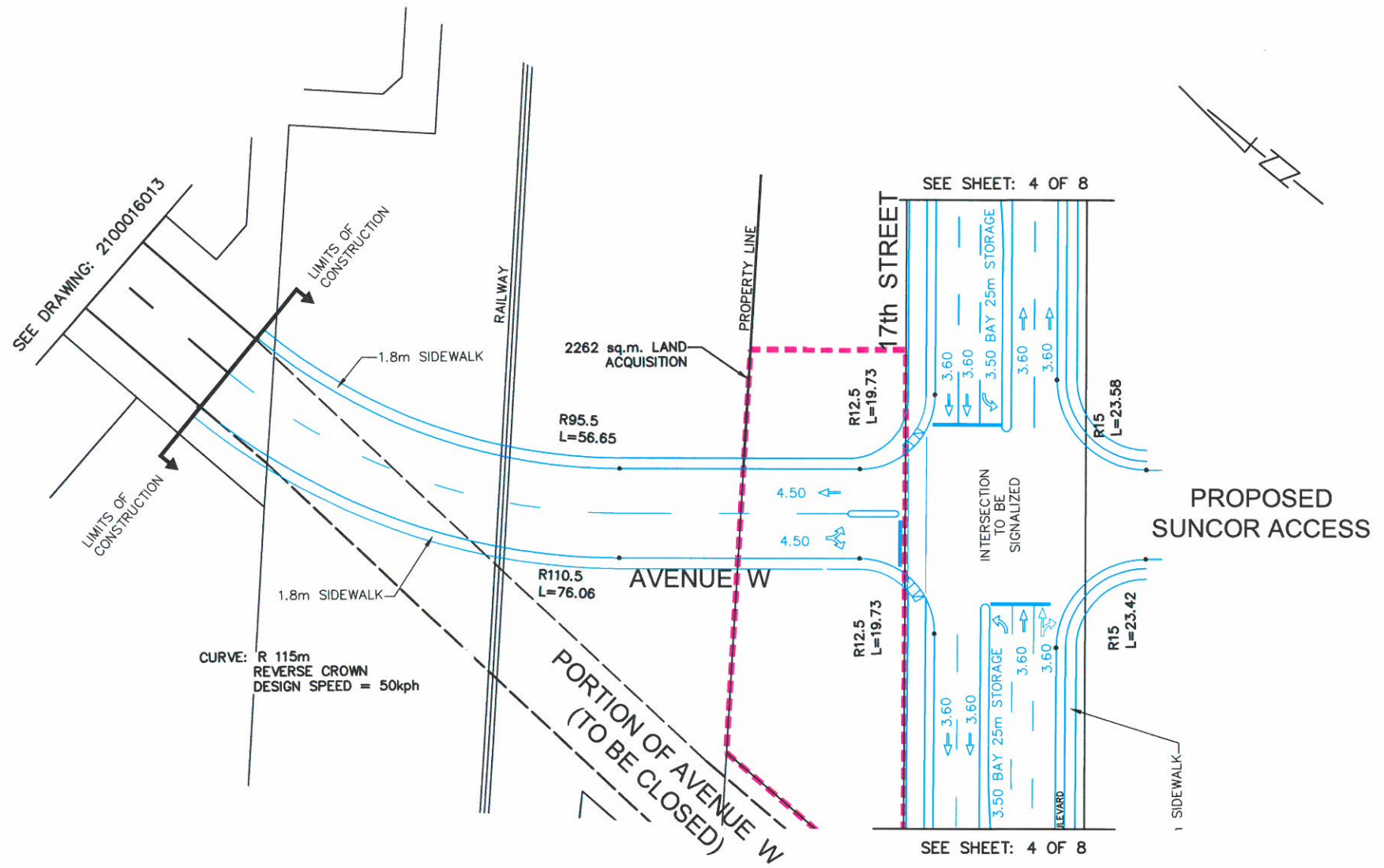

LEGEND

EXISTING CONDITIONS = BLACK
 REVISED 4 LANE CROSS SECTION = BLUE

LANE WIDTH LABELLING

LANE WIDTH LABELLING IS EXCLUSIVE OF GUTTER AND OFFSET DIMENSIONS

FUNCTIONAL

PROJECT NO. 75492

TRANSPORTATION DIVISION - FUNCTIONAL	
ENGINEER	DATE
ENGINEER	DATE 22.2.2018
ENGINEER	DATE
ENGINEER	DATE
DRAWN BY AMR	DATE 2018-JAN-04



FUNCTIONAL INTERSECTION MODIFICATION

SOUTH WEST TRANSPORTATION STUDY
 AVENUE W DEFLECTION
 FUNCTIONAL PLAN

DIRECTOR		DATE Mar. 5/18	
SCALES:		1:1000	
HOR.			
VERT.			
SHEET NO	PLAN NO.		
5 OF 8	249-0043-001r001		

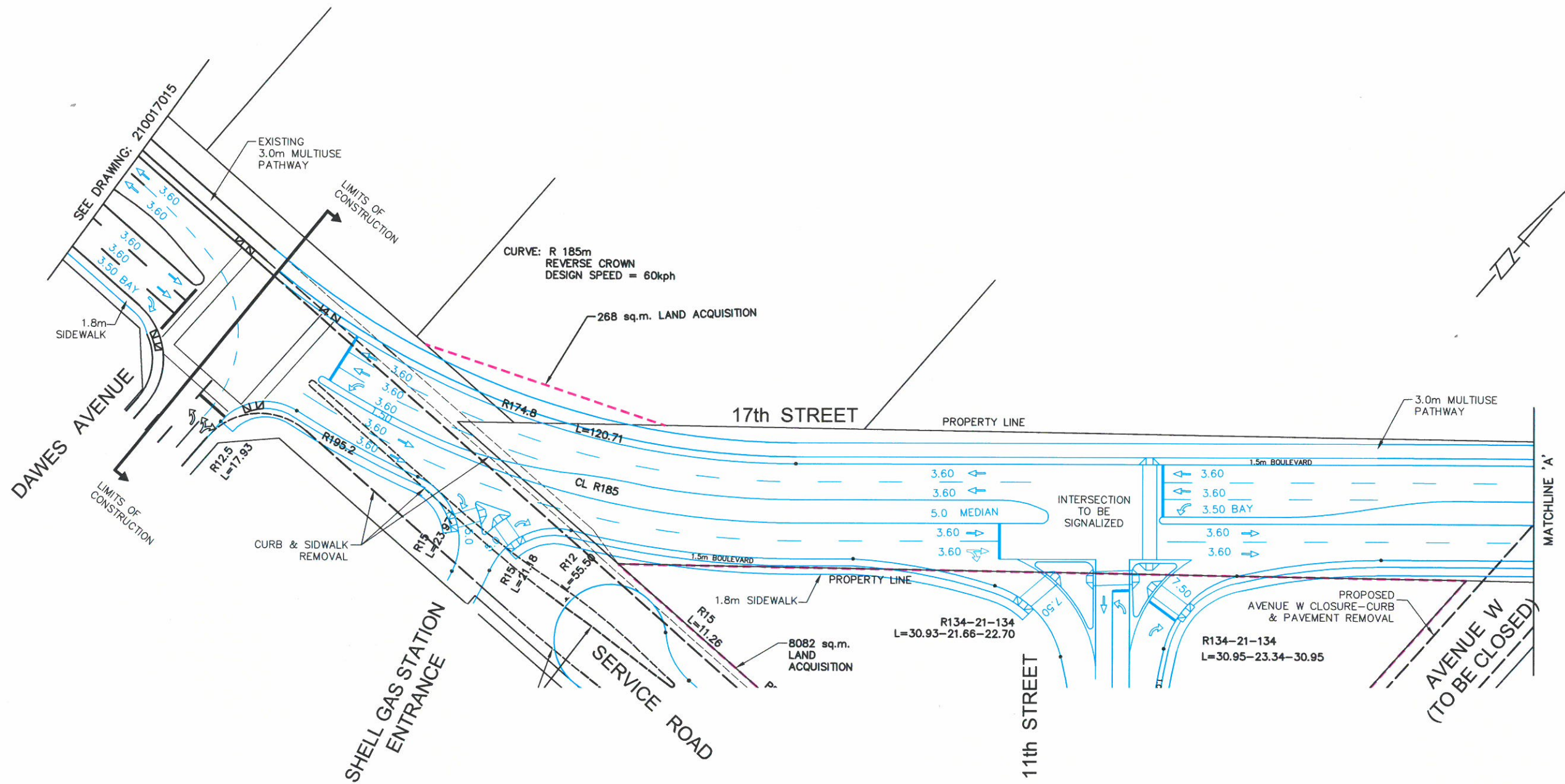

LEGEND

EXISTING CONDITIONS = BLACK
 REVISED 4 LANE CROSS SECTION = BLUE

LANE WIDTH LABELLING

LANE WIDTH LABELLING IS EXCLUSIVE OF GUTTER AND OFFSET DIMENSIONS

FUNCTIONAL

PROJECT NO. 75492

TRANSPORTATION DIVISION - FUNCTIONAL	
ENGINEER	DATE
ENGINEER	DATE 2018-12-28/18
ENGINEER	DATE
ENGINEER	DATE
DRAWN BY AMR	DATE 2018-JAN-04



FUNCTIONAL INTERSECTION MODIFICATION

SOUTH WEST TRANSPORTATION STUDY
 7th STREET EAST - DAWES AVENUE TO 90m EAST OF 11th STREET
 FUNCTIONAL PLAN

DIRECTOR	<i>[Signature]</i>
SCALES:	HOR. 1:1000
VERT.	
SHEET NO.	6 OF 8
PLAN NO.	249-0043-001r001
DATE	Mar. 5/18

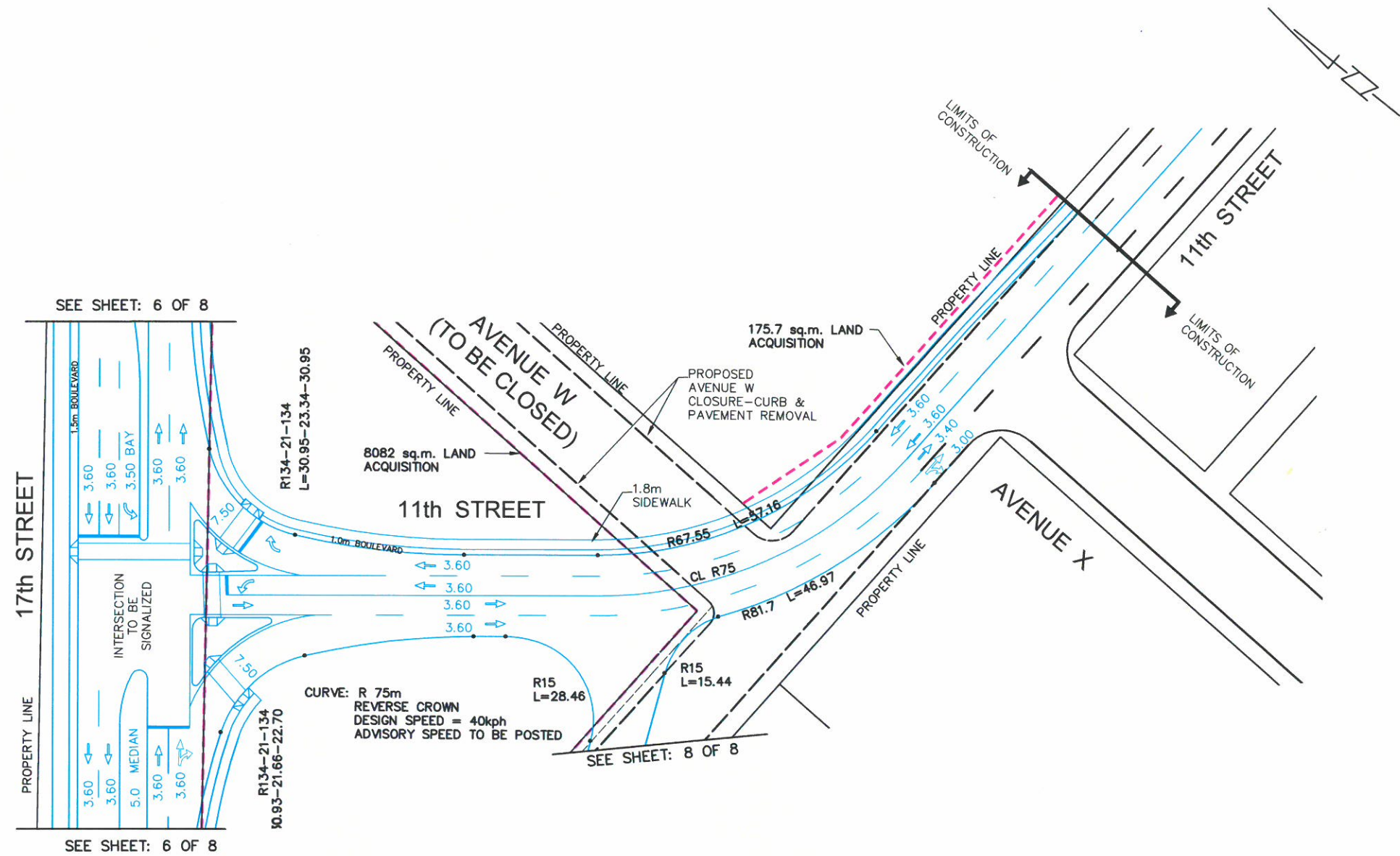

LEGEND

EXISTING CONDITIONS = BLACK
 REVISED 4 LANE CROSS SECTION = BLUE

LANE WIDTH LABELLING

LANE WIDTH LABELLING IS EXCLUSIVE OF GUTTER AND OFFSET DIMENSIONS

FUNCTIONAL

PROJECT NO. 75492

TRANSPORTATION DIVISION - FUNCTIONAL	
ENGINEER	DATE
ENGINEER	DATE
ENGINEER	DATE
ENGINEER	DATE
DRAWN BY: AMR	DATE: 2018-JUN-04



FUNCTIONAL INTERSECTION MODIFICATION

SOUTH WEST TRANSPORTATION STUDY
 11th STREET DEFLECTION
 FUNCTIONAL PLAN

DIRECTOR	<i>[Signature]</i>
SCALES:	
HOR.	1:1000
VERT.	
SHEET NO.	7 OF 8
PLAN NO.	249-0043-001r001
DATE	Mo 15/18

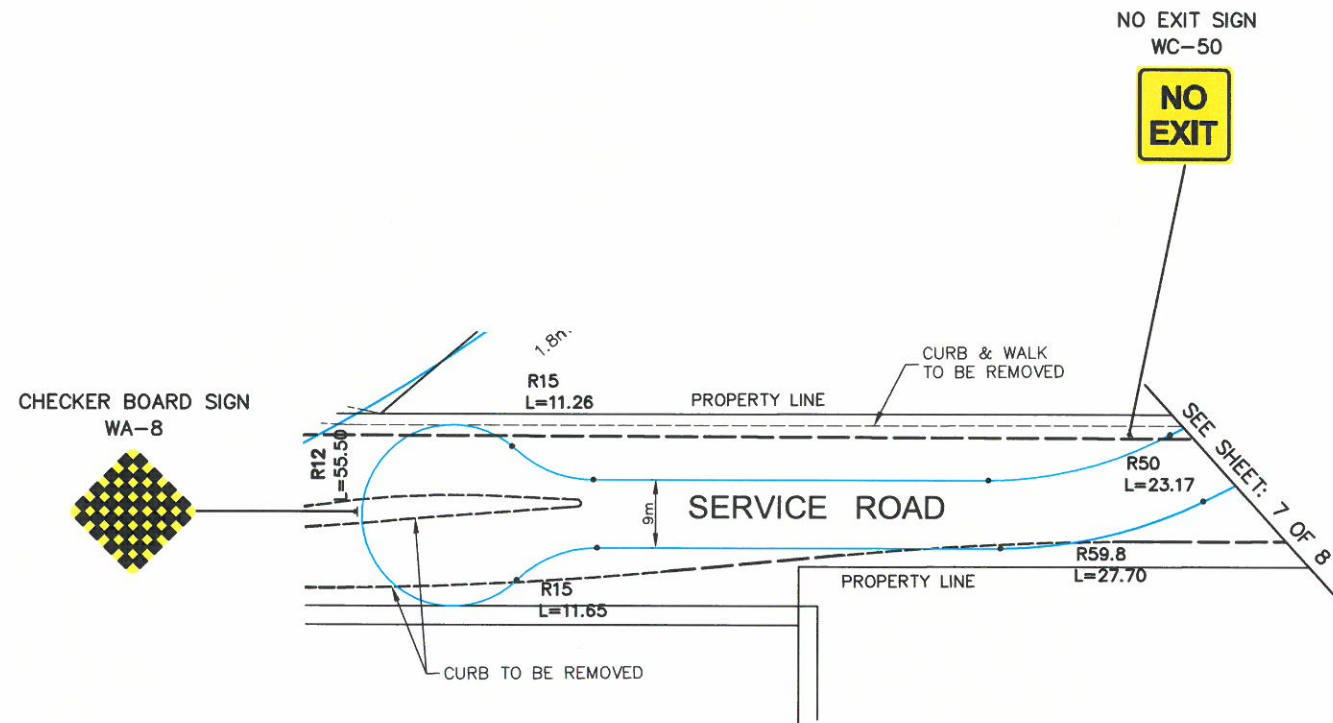

LEGEND

EXISTING CONDITIONS = BLACK
 REVISED 4 LANE CROSS SECTION = BLUE

LANE WIDTH LABELLING

LANE WIDTH LABELLING IS EXCLUSIVE OF GUTTER AND OFFSET DIMENSIONS

FUNCTIONAL

PROJECT NO. 75492

TRANSPORTATION DIVISION - FUNCTIONAL	
ENGINEER	DATE
ENGINEER	DATE 2018-12-28
ENGINEER	DATE
ENGINEER	DATE
DRAWN BY AMR	DATE 2018-JUN-04



FUNCTIONAL INTERSECTION MODIFICATION

SOUTH WEST TRANSPORTATION STUDY
 SERVICE ROAD
 FUNCTIONAL PLAN

DIRECTOR		DATE	
SCALES : 1:1000		Mar. 5/18	
SHEET NO	PLAN NO.	DATE	
8 OF 8	249-0043-001r001		

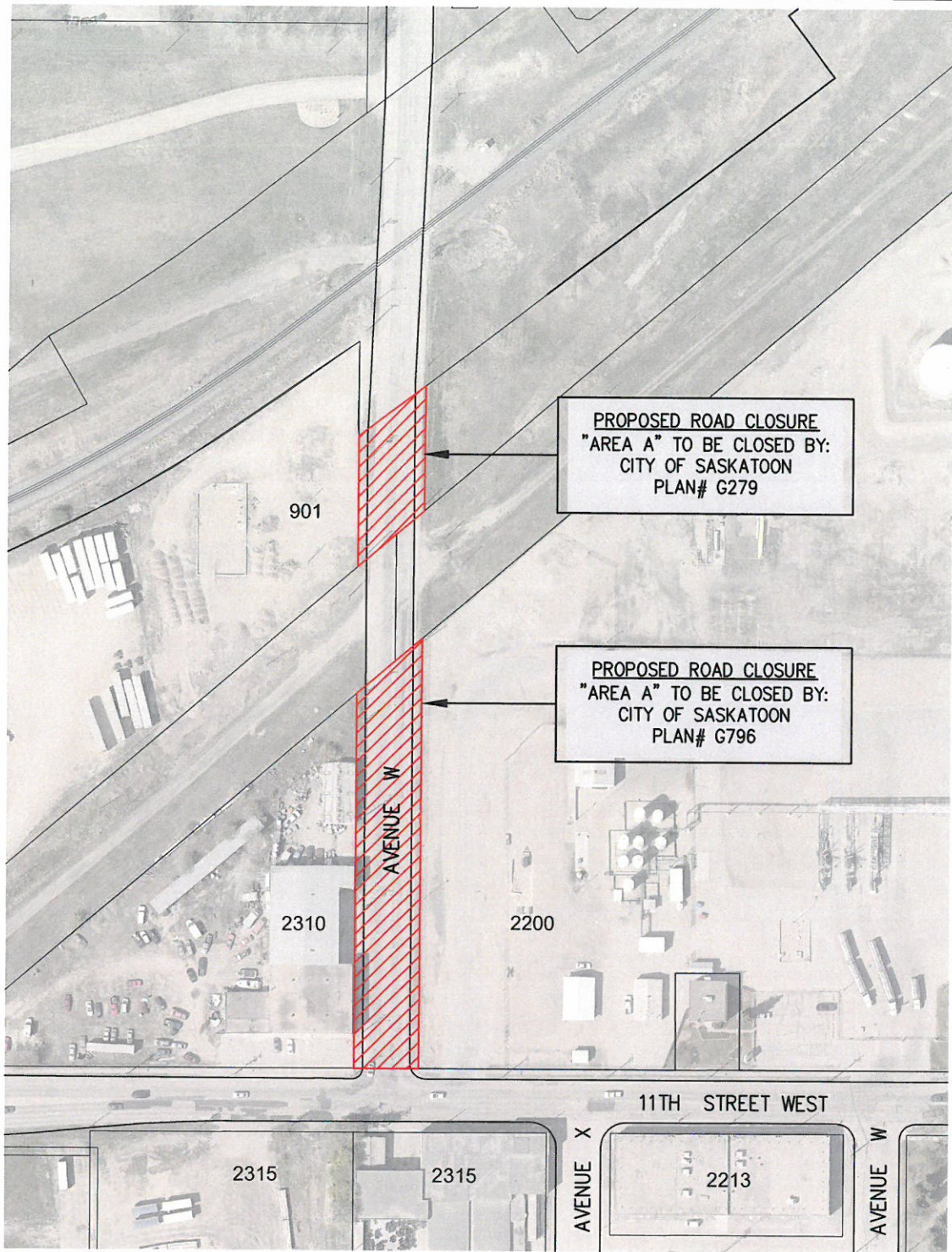

PROPOSED ROAD CLOSURE
 AREA = 5419m²

PLAN DESCRIPTION/REVISIONS		 City of Saskatoon Transportation & Utilities Department	APPROVED
4			
3		CHIEF ENGINEER ENGINEER PLAN NO. 240-0043-007r001	
2			
1			
DRAWN BY <u>AMR</u> DATE <u>2018-FEB-05</u> SCALE : HOR. <u>1:2000</u> VERT. <u>"</u>		AVENUE W PROPOSED ROAD CLOSURE	

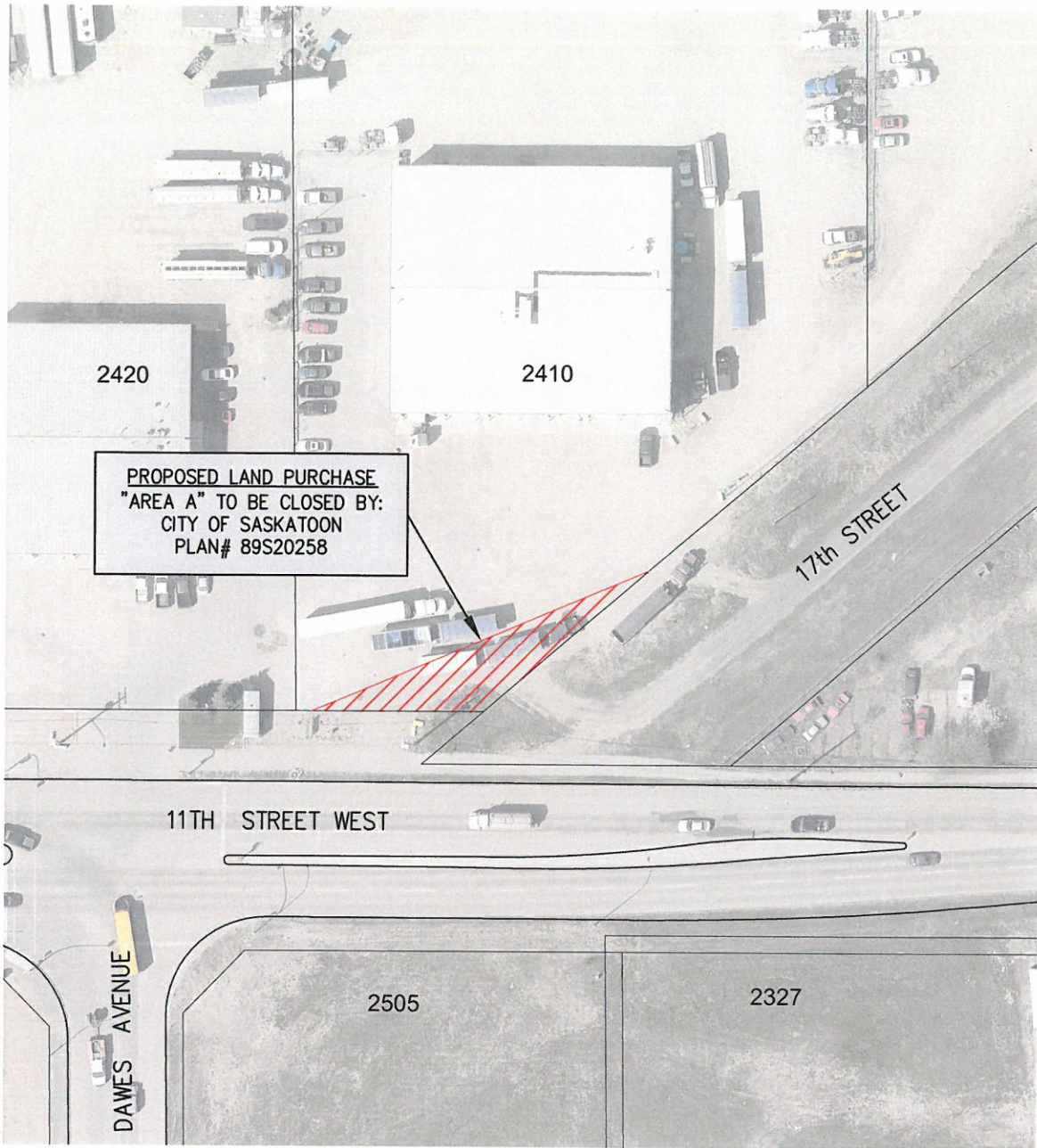
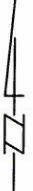

PROPOSED LAND PURCHASE
 "AREA A" TO BE CLOSED BY:
 CITY OF SASKATOON
 PLAN# 89S20258



PROPOSED LAND ACQUISITION
 AREA = 268m²

PLAN DESCRIPTION/REVISIONS		 City of Saskatoon Transportation & Utilities Department	APPROVED
4			
3		PROPERTY ACQUISITION 11th STREET/17th STREET & DAWES AVENUE	CHIEF ENGINEER
2			
1			ENGINEER
DRAWN BY <u>AMR</u>		PLAN NO. 240-0043-008r001	
DATE <u>2018-FEB-05</u>			
SCALE : HOR. <u>1:1000</u> VERT. <u>"</u>			

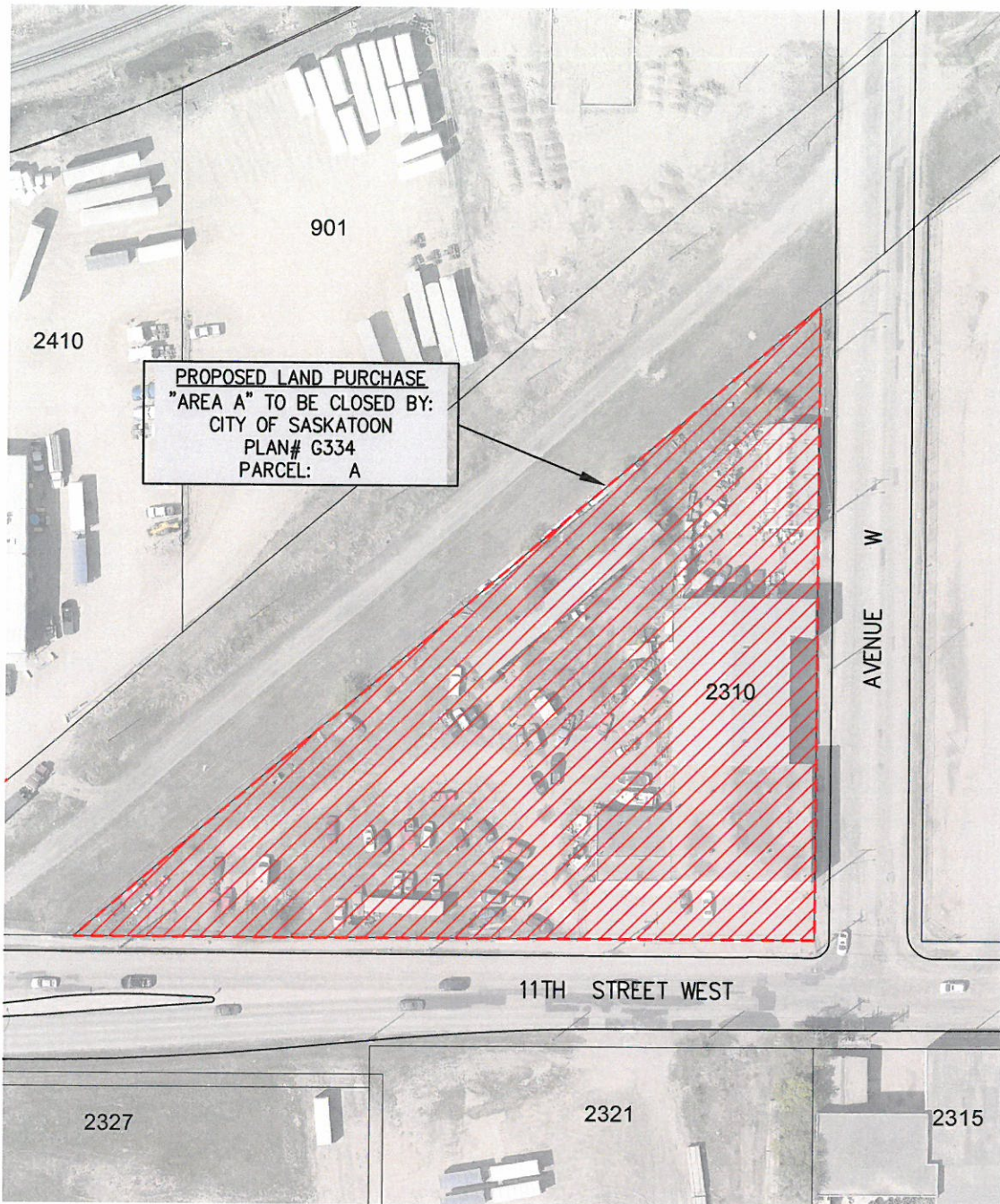

PROPOSED LAND ACQUISITION
 AREA = 8082m²

PLAN DESCRIPTION/REVISIONS	
4	
3	
2	
1	
DRAWN BY <u>AMR</u>	
DATE <u>2018-FEB-05</u>	
SCALE : HOR. <u>NTS</u> VERT. <u>"</u>	



City of Saskatoon
 Transportation & Utilities Department

PROPERTY ACQUISITION
 11th STREET & AVENUE W

APPROVED

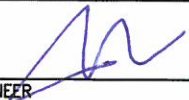
 CHIEF ENGINEER

ENGINEER

PLAN NO. 240-0043-009r001

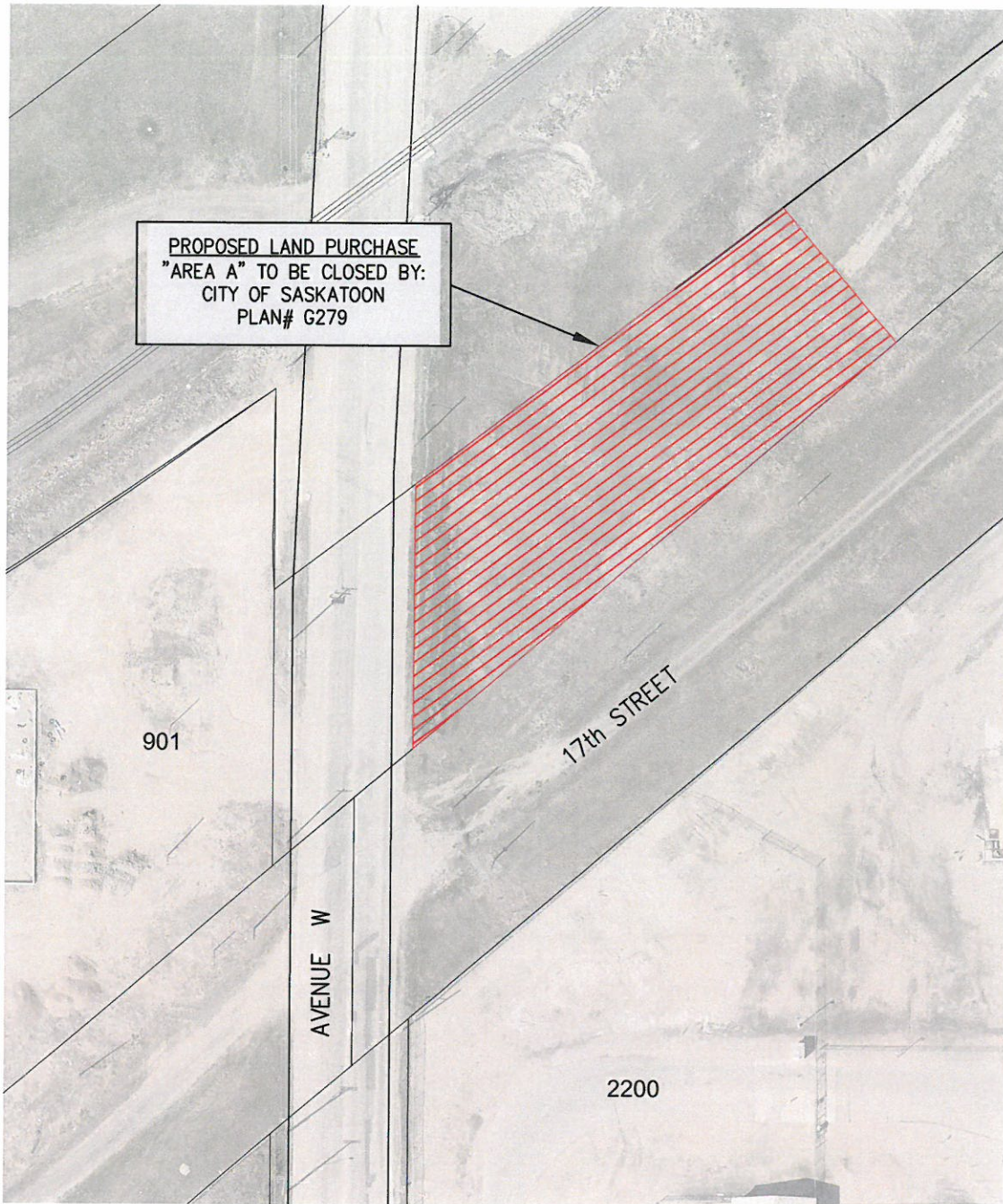

PROPOSED LAND PURCHASE
 "AREA A" TO BE CLOSED BY:
 CITY OF SASKATOON
 PLAN# G279

901

AVENUE W

17th STREET

2200





PROPOSED LAND ACQUISITION
 AREA = 2262m²

PLAN DESCRIPTION/REVISIONS	
4	
3	
2	
1	

DRAWN BY AMR
 DATE 2018-FEB-05
 SCALE : HOR. 1:1000 VERT. "



PROPERTY ACQUISITION
 17th STREET & AVENUE W

APPROVED

CHIEF ENGINEER

ENGINEER
PLAN NO. 240-0043-010r001



PROPOSED LAND PURCHASE
 "AREA A" TO BE CLOSED BY:
 CITY OF SASKATOON
 PLAN# G796



PROPOSED LAND ACQUISITION
 AREA = 175.7m²

PLAN DESCRIPTION/REVISIONS	 City of Saskatoon Transportation & Utilities Department	APPROVED
4		 CHIEF ENGINEER
3		
2		
1		
DRAWN BY <u>AMR</u> DATE <u>2018-FEB-05</u>	PROPERTY ACQUISITION 11th STREET & SUNCOR ENERGY OIL & GAS	 ENGINEER
SCALE : HOR. <u>1:1000</u> VERT. <u>"</u>		PLAN NO. 240-0043-011r001

Appendix E

Functional Plan of Near Term Improvements along 17th Street



17th Street Traffic Calming